



## ACCESSORI PER ORNITOLOGIA E ANIMALI

*Accessories for ornithology and animals  
Accesorios por ornitología y animales  
Accessoires pour l'ornithologie et animaux*

## STORIA DELL'AZIENDA

Partner affidabile con oltre 35 anni di esperienza. La 2GR nasce nel 1980 come azienda produttrice di stampi per materie plastiche, per conto terzi. Nel 1985 parallelamente all'attività di progettazione e costruzioni stampi, nasce la linea di prodotti per l'ornitologia che la 2GR inizia a produrre e commercializzare in proprio.

Fin da subito gli articoli 2GR spiccarono per qualità e facilità di montaggio e utilizzo, ma la scelta che si rivelò vincente, fu la ricerca di materiali assolutamente NON tossici. Le esigenze di mercato e la creatività dello staff tecnico consente di ampliare ed arricchire la gamma dei prodotti; il continuo confronto con gli allevatori ci consente un'attenzione progettuale e produttiva costante. Oggi la 2GR è presente in tanti mercati del mondo con oltre 400 prodotti per l'ornitologia, cane, gatto, tartarughe e criceti per il massimo confort dei nostri piccoli amici.

## THE HISTORY OF THE FACTORY

Reliable partner for over 35 years. The 2GR was born on the 1980 as a factory producing moulds for plastic materials on behalf of a third party. In the 1985, together with the moulds' planning and producing activity, the 2GR creates its own ornitology range of products. The 2GR pays attention in choosing non toxic materials, high quality finishing, easy installation and use.

The market needs and the staff's creativity allow 2GR to enrich its range of products; the constant dialogue with breeders gives 2GR the possibility to pay attention to project making and constant production. Nowadays, 2GR is present in many markets around the world with over 400 products for ornitology, cats, dogs, turtle and hamsters and the maximum confort for our little friends.

## HISTOIRE DE LA SOCIÉTÉ

Partenaire fiable avec plus de 35 années d'expérience. 2GR a été fondée en 1980 en tant que producteur de moules pour matériaux plastiques pour des tiers. En 1985, en parallèle à la conception et la fabrication de moules, vient la ligne de produits pour l'ornithologie que 2GR commence à produire et à commercialiser en propre.

La gamme de produits comprend une large gamme d'accessoires pour les oiseaux, comme des abreuvoirs, des mangeoires, des accessoires de transport, des baignoires et des nids; ainsi que des produits pour les petits animaux de compagnie comme les chiens et les chats, les tortues et les rongeurs, tels que des bols, des accessoires de transport, de la litière, des vivariums pour tortues et des cages pour hamsters. Depuis le début, les articles 2GR ont été appréciés pour leur qualité et leur facilité d'installation et d'utilisation, mais le choix qui a fait ses preuves a été la recherche de matériaux absolument non toxiques, une grande attention aux réglementations en vigueur concernant le transport des animaux, ce qui a amené 2GR à être le premier fabricant de produits de transport en plastique pour les oiseaux. Les exigences du marché et la créativité de l'équipe technique permettent d'élargir et d'enrichir la gamme de produits et le contact permanent avec les éleveurs nous permet d'assurer une attention constante dans la conception et la production. Aujourd'hui 2GR est présent sur de nombreux marchés dans le monde avec plus de 400 produits pour l'ornithologie, les chiens, les chats, les tortues et les hamsters pour assurer le confort maximum de nos petits amis.

## HISTORIA DE LA EMPRESA

Un socio fiable mas 35 años. 2GR nace en el año 1980 como empresa especializada en la fabricación a terceros de modelos para inyección de materia plastica. En 1985, paralelamente a la actividad de proyectar y construir modelos, nace una línea de productos para la ornitología.

La empresa 2GR comienza a producir y comercializar productos desde su propia estructura, utilizando materiales no tóxicos, acabados de calidad, praticos y faciles de montar y utilizar.

Con la exigencia del mercado y la creatividad del equipo técnico logramos ampliar y enriquecer la gama de productos, así como la continua relación con los criadores logra que exista una atención y tension proyectiva y productiva constante.

Al día de hoy, la empresa 2GR esta presente en muchos y diferentes mercados del mundo con mas de 400 productos especializados para ornitología, perros, gatos, tortugas y roedores con el fin de ofrecer el maximo confort a nuestros pequeños amigos.





# UCCELLI

BIRDS / PÁJAROS / OISEAUX

## Trasportini 6

Transport  
Trasportin  
Cage de transport

## Beverini 23

Drinkers  
Bevederos  
Fontaines

## Mangiatoie 32

Feeders  
Comederos  
Mangeoires

## Bagni 47

Baths  
Bañeras  
Bains

## Nidi 49

Nests  
Nidos  
Nids

## Gabbie 61

Cages  
Jaulas  
Cages

## Fondi 88

Bottoms  
Fondos  
Fonds

## Accessori 58

Accessories  
Accesorios  
Accessoires







## TINO



TUTTI I NOSTRI ARTICOLI DA TRASPORTO RISPETTANO LE NUOVE NORMATIVE

## TINO ECONOMY



### Art. 235

— cm. 38 × 39 × 18h  
**Tino Economy senza interno estraibile**  
 Tino Economy without internal grey case  
 Tino Economy sin caja interna gris  
 Tino Economy sans caisse interne grise



### Art. 207

— cm. 38 × 39 × 3h  
**Coperchio con maniglia**  
 Lid with handle  
 Tapa con asa  
 Couvercle avec poignée



### Art. 200

— cm. 38 × 39 × 18h  
**Trasportino con griglia fissa e mangiatoia esterna**  
 Transport cage with fixed grill and external feeder  
 Transportin con reja fija y comederos externos  
 Cage de transport avec grille fixe et mangeoires extérieures



### Art. 250

**Interno completo dell'Art. 200**  
 Interior complete of Art. 200  
 Interior completo para Art. 200  
 Interieur complet pour Art. 200





### Art. 201

— cm. 38 x 39 x 18h

**Trasportino con griglia fissa e mangiatoia interna**  
 Transport cage with fixed grill and internal feeder  
 Transportin con reja fija y comederos internos  
 Cage de transport avec grille fixe et mangeoires internes

## TINO

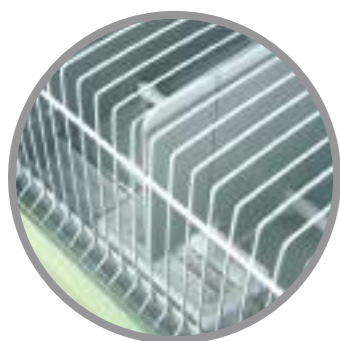

### Art. 202

— cm. 38 x 39 x 18h -> 35h

**Trasportino con griglia Telescopica**  
 Transport cage with Telescopic grill  
 Transportin con reja Telescópica  
 Cage de transport avec grille telescopique

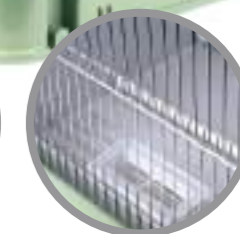

**IDONEO PER MOSTRE  
 SCAMBIO**

### Art. 251

**Interno completo dell'Art. 201**  
 Interior complete of Art. 201  
 Interior completo para Art. 201  
 Interieur complet pour Art. 201

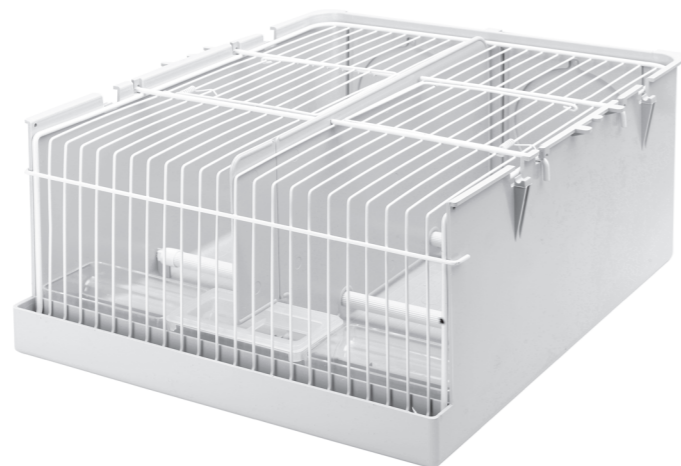

### Art. 218

**Scatola esterna del Tino**  
 Tino 's external case  
 Caja externa de Tino  
 Caisse externe du Tino



### Art. 252

**Interno completo dell'Art. 202**  
 Interior complete of Art. 202  
 Interior completo para Art. 202  
 Interieur complet pour Art. 202





## MAXI TINO

IDEALE PER MOSTRE SCAMBIO

### Art. 456

— cm. 66,8 × 34,3 × 21h -> 30h  
**Maxi tino con griglia Telescopica**  
 Maxi tino con griglia Telescopica  
 Maxi tino with Telescopic grill  
 Maxi Tino con rejilla Telescópica  
 Maxi Tino avec grille telescopique

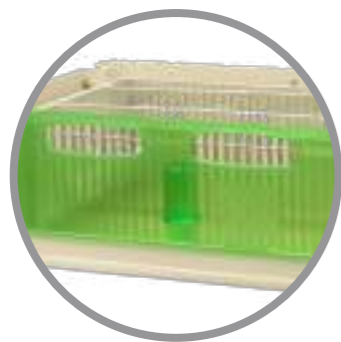
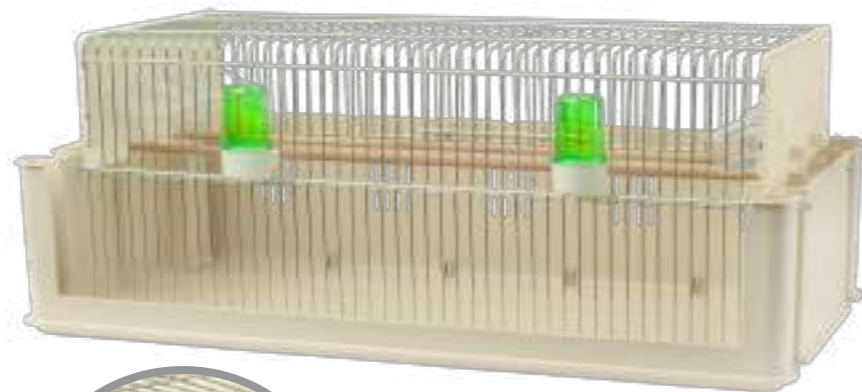

### Art. 204

— cm. 66,8 × 34,3 × 21h  
**Trasportino per ondulati a 5 posti**  
 Transport cage for budgerigar 5 spaces  
 Transportin para periquito a 5 lugares  
 Cage de transport pour perokeet avec 5 lieux



### Art. 217

— cm. 66,8 × 34,3 × 2,5h  
**Coperchio per Maxi-Tino**  
 Maxi-Tino's cover  
 Tapa para Maxi-Tino  
 Couvercle pour Maxi-Tino



### Art. 205

— cm. 66,8 × 34,3 × 21h  
**Trasportino per soggetti di media taglia aperto sul retro**  
 Transport cage for medium sizes bird open in the back side  
 Transportin para parajos tamaños mediano abierto posteriormente  
 Cage de Transport pour oiseaux de moyenne taille ouverte a l'arriere

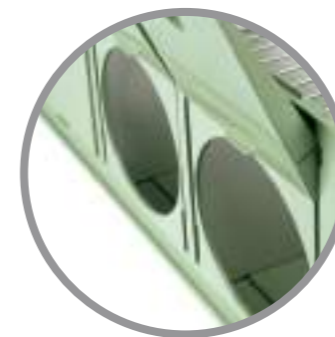

### Art. 233

— cm. 66,8 × 34,3 × 21h  
**Trasportino per soggetti di media taglia chiuso sul retro**  
 Transport cage for medium sizes bird closed in the back side  
 Transportin para parajos tamaños mediano cerrado posteriormente  
 Cage de Transport pour oiseaux de moyenne taille fermé a l'arriere





## SECONDINO

Trasporto singolo / Single transport / Transporte singolo / Transport individuel

### Art. 220



— cm. 16 × 11,7 × 14,6h

Trasporto singolo per taglie piccole  
Single transport cage for small size  
Transporte unico para tallas pequeñas  
Cage de transport pour petites tailles



TUTTI I NOSTRI ARTICOLI DA TRASPORTO RISPETTANO LE NUOVE NORMATIVE



### Art. 203

— cm. 38 × 39 × 18h  
Tino + n. 6 Secondino



### Art. 234

— cm. 66,8 × 34,3 × 21h  
Maxi Tino + n. 10 Secondini



### Art. 239

cm. 66,8 × 34,3 × 21h  
Maxi Tino vuoto con supporti  
Maxi Tino empty with support  
Maxi Tino vacío con soporte  
Maxi Tino vide avec soutient



## VALIGIA

### Art. 225

— cm. 66,8 × 21 × 36h  
**Valigia completa di 10 Secondini**  
 Complete case with 10 Secondini  
 Maleta con 10 Secondini  
 Valise complet avec 10 Secondini



### Art. 226

— cm. 66,8 × 21 × 36h  
**Valigia vuota**  
 Empty case  
 Maleta vacia  
 Valise vide



## SECONDINO MEDIO

Trasporto singolo medio / Secondino Medium-size / Secondino Mediano / Secondino Moyen

### Art. 244

— cm. 20 × 11 × 14 h.  
**Trasportino singolo per taglie medie**  
 Single transport cage for medium size  
 Transporte singolo para talla media  
 Cage de transport pour tailles moyenne



### Art. 256

— cm. 37 × 22 × 43h  
**Valigia 6 posti**  
 Case with 6 places  
 Maleta con 6 lugares  
 Valise avec 6 lieux



### Art. 261

**Valigia vuota con 6 posti**  
 Empty case with 6 places  
 Maleta vacia con 6 lugares  
 Valise vide avec 6 lieux



### Art. 276

**Copertura x valigia 6 posti**  
 Cover for 6 places case  
 Cobertura para maleta con 6 lugares  
 Couverture pour valise avec 6 lieux





**Art. 257**

— cm. 48 × 22 × 43h  
**Valigia 8 posti**  
 Case with 8 places  
 Maleta con 8 lugares  
 Valise avec 8 lieux



**Art. 259**

— cm. 71 × 22 × 62h  
**Valigia 18 posti**  
 Case with 18 places  
 Maleta con 18 lugares  
 Valise avec 18 lieux



**Art. 262**

**Valigia vuota 8 posti**  
 Empty case with 8 places  
 Maleta vacia con 8 lugares  
 Valise vide avec 8 lieux



**Art. 277**

**Copertura x valigia 8 posti**  
 Cover for 8 places case  
 Cobertura para maleta con 8 lugares  
 Couverture pour valise avec 8 lieux



**Art. 264**

**Valigia vuota 18 posti**  
 Empty case with 18 places  
 Maleta vacia con 18 lugares  
 Valise vide avec 18 lieux



**Art. 258**

— cm. 71 × 22 × 43h  
**Valigia 12 posti**  
 Case with 12 places  
 Maleta con 12 lugares  
 Valise avec 12 lieux



**Art. 263**

**Valigia vuota 12 posti**  
 Empty case with 12 places  
 Maleta vacia con 12 lugares  
 Valise vide avec 12 lieux



**Art. 278**

**Copertura x valigia 12 posti**  
 Cover for 12 places case  
 Cobertura para maleta con 12 lugares  
 Couverture pour valise avec 12 lieux



**Art. 279**

**Copertura x valigia 18 posti**  
 Cover for 18 places case  
 Cobertura para maleta con 18 lugares  
 Couverture pour valise avec 18 lieux





### Art. 273

— cm. 75 × 45 × 110h  
**Carrello con 60 secondini medi**  
*Trolley with 60 medium-size Secondini*  
*Carrito con 60 Secondini medianos*  
*Chariot avec 60 Secondini*



### Art. 273/A

— cm. 75 × 45 × 43h  
**Modulo superiore con 24 Secondini**  
*Upper module with 24 Secondini*  
*Modulo superior con 24 Secondini*  
*Module supérieur avec 24 Secondini*



### Art. 273/B

— cm. 75 × 45 × 70h  
**Modulo inferiore con 36 Secondini**  
*Lower module with 36 Secondini*  
*Modulo inferior con 36 Secondini*  
*Module basse avec 36 Secondini*

### Art. 273/C

— cm. 75 × 45 × 6h  
**Comp. trasformazione ruote removibili**  
*Additional part for removable wheels*  
*Componente para ruedas removable*  
*Part supplémentaire pour roues amovibles*



### Art. 231

**Carrello con ruote per Maxi Tino**  
*Trolley with wheels for Maxi Tino*  
*Carrito con ruedas para Maxi Tino*  
*Chariot avec roues pour Maxi Tino*

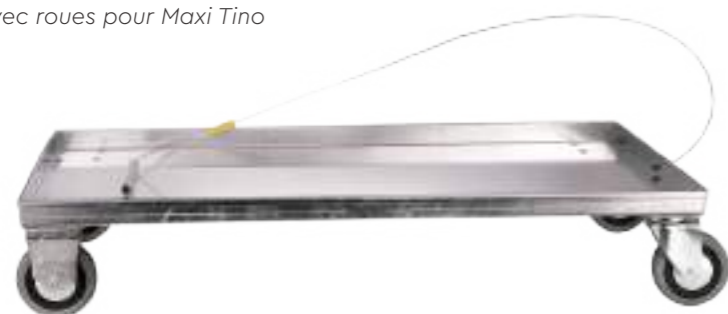

## SECONDINO MAXI

### Art. 242



— cm. 31 × 11,5 × 16h  
**Trasportino singolo per taglie grandi**  
*Single transport cage for big size*  
*Transporte singolo para talla grande*  
*Cage de transport pour tailles grand*



**NO GRIGLIA SUL FONDO**  
**NO GRILL ON THE BOTTOM**



**RISPETTA LE NUOVE  
NORMATIVE**

### Art. 245

— cm. 66,8 × 34,3 × 21h  
**Maxi Tino + n. 5 Secondini Maxi**





**Art. 214**

— cm. 10 × 5 × 4h  
**Mangiatoia rettangolare**  
 Rectangular feeder  
 Comedero rectangular  
 Mangeoire rectangulaire



**Art. 206**

cc. 100  
**Beverino rettangolare**  
 Rectangular drinker  
 Bebedero rectangular  
 Fontaine rectangulaire



**Art. 215**

**Parete estraibile per Tino**  
 Tino's removable wall  
 Pared extraíble para Tino  
 Amovible cloison pour Tino



**Art. 227**

**Parete estraibile per Maxi-Tino**  
 Maxi-Tino's removable wall  
 Pared extraíble para Maxi-Tino  
 Amovible cloison pour Maxi-Tino



**Art. 248**

cc. 50  
**Beverino/Mangiatoia per art. 242 e 244**  
 Drinker/Feeder for art. 242 and 244  
 Bebedero/Comedero para art. 242 y 244  
 Fontaine/Mangeoire pour art. 242 et 244



COMPATIBILE CON  
 ART. 235

**Art. 236**

**Divisoria per Tino Economy**  
 Tino Economy's dividing wall  
 Divisoria para Tino Economy  
 Cloison pour Tino Economy



COMPATIBILE CON  
 ART. 200-201

**Art. 209**

**Divisoria per Tino**  
 Tino's Dividing wall  
 Divisorio para Tino  
 Cloison pour Tino



**Art. 247**

**Gancio per coperchio valigia art. 225**  
 Hook for case's cover art. 225  
 Gancho para tapa maleta art. 225  
 Crochet pour couvercle de la valise art. 225



**Art. 210**

**Gancio**  
 Hook  
 Gancho  
 Crochet



PER MAXI TINO  
 SENZA POSATOI

**Art. 228/C**

**Divisoria per Maxi-Tino**  
 Maxi-Tino's dividing wall  
 Divisoria para Maxi-Tino  
 Cloison pour Maxi-Tino



COMPATIBILE CON  
 ART. 204-205-233

**Art. 228/A**

**Divisoria per Maxi-Tino**  
 Maxi-Tino's dividing wall  
 Divisoria para Maxi-Tino  
 Cloison pour Maxi-Tino



**Art. 216**

— cm. 29  
**Posatoio per Art. 200-201-202**  
 Perch for Art. 200-201-202  
 Posaderos para Art. 200-201-202  
 Perchoir pour Art. 200-201-202



**Art. 249**

— cm. 35,5  
**Posatoio per Art. 235**  
 Perch for Art. 235  
 Posaderos para Art. 235  
 Perchoir pour Art. 235



**Art. 237**

**Supporti per Secondino**  
 Supports for Secondino  
 Soportes para Secondino  
 Soutien pour Secondino



**Art. 208**

**Ruote**  
 Wheels  
 Ruedas  
 Roues

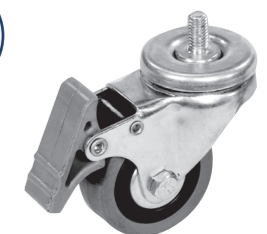

**Art. 238**

**Griglia per Art. 235**  
 Grill for Art. 235  
 Reja para Art. 235  
 Grille pour Art. 235

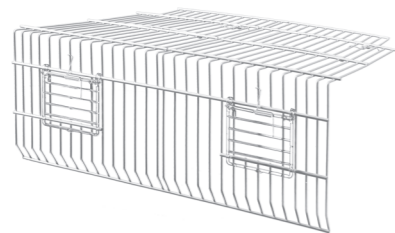

**Art. 211**

**Griglia per Art. 200**  
 Grill for Art. 200  
 Reja para Art. 200  
 Grille pour Art. 200



**Art. 212**

**Griglia per Art. 201**  
 Grill for Art. 201  
 Reja para Art. 201  
 Grille pour Art. 201

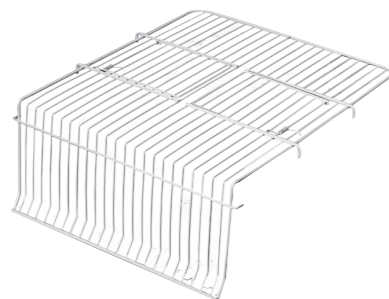

**Art. 213**

**Griglia per Art. 202**  
 Grill for Art. 202  
 Reja para Art. 202  
 Grille pour Art. 202

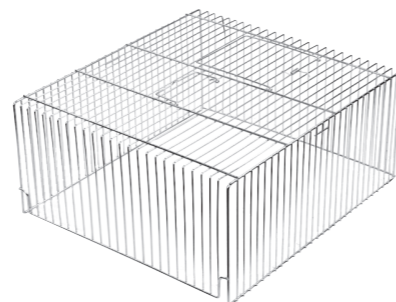

**Art. 229**

**Griglia per art.204**  
 Grill for art. 204  
 Reja para art. 204  
 Grille pour art. 204

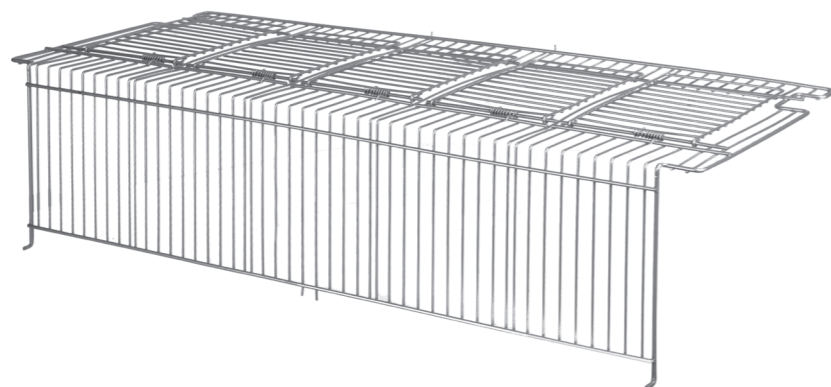

**Art. 230**

**Griglia per art.205**  
 Grill for art. 205  
 Reja para art. 205  
 Grille pour art. 205



**Art. 146**

**cc. 40**  
**Beverino per medicinali**  
 Medicine dispenser  
 Bebedero para medicamentos  
 Fontaine pour médicaments

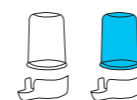

**Art. 274**

**cc. 72**  
**Sifone Aosta corto**  
 Aosta short siphon  
 Bebedero corto Aosta  
 Fontaine court Aosta

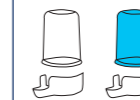

**Art. 284**

**cc. 105**  
**Sifone Aosta lungo**  
 Aosta long siphon  
 Bebedero Aosta largo  
 Fontaine long Aosta

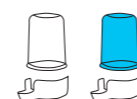

**Art. 184**

**cc. 200**  
**Sifone Leo**  
 Leo siphon  
 Bebedero Leo  
 Fontaine Leo

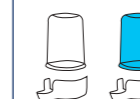

**Art. 386**

**cc. 260**  
**Sifone Venezia**  
 Venezia Siphon  
 Bebedero Venezia  
 Fontaine Venezia



**Art. 387**

**cc. 400**  
**Sifone Pisa**  
 Pisa Siphon  
 Bebedero Pisa  
 Fontaine Pisa





**Art. 240**

cc. 20  
**Beverino Dino**  
 Dino drinker  
 Bebedero Dino  
 Fontaine Dino

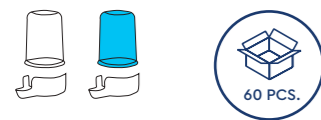

**Art. 221**

cc. 30  
**Beverino Secondino**  
 Secondino drinker  
 Bebedero Secondino  
 Fontaine Secondino

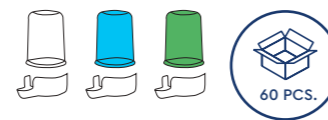

**Art. 131**

cc. 140  
**Sifone Marta**  
 Marta siphon  
 Bebedero Marta  
 Fontaine Marta

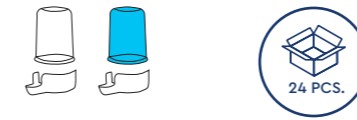

**Art. 275**

cc. 200  
**Sifone Ferrara**  
 Ferrara siphon  
 Bebedero Ferrara  
 Fontaine Ferrara

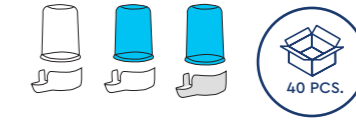

**Art. 158**

cc. 72  
**Beverino corto lusso**  
 Short luxury drinker  
 Bebedero corto lujo  
 Fontaine court luxe

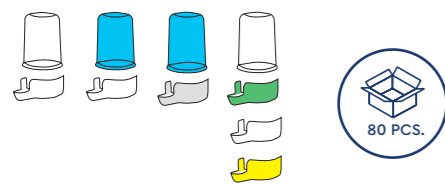

**Art. 128**

cc. 105  
**Beverino lungo lusso**  
 Long luxury siphon  
 Bebedero largo lujo  
 Fontaine long luxe

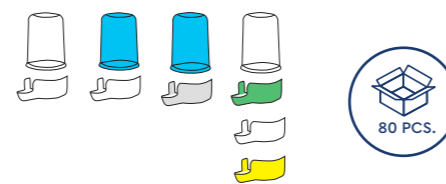

**Art. 380**

cc. 260  
**Sifone Amalfi**  
 Amalfi siphon  
 Bebedero Amalfi  
 Fontaine Amalfi

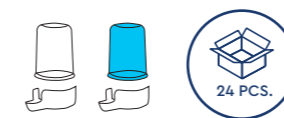

**Art. 222**

cc. 105  
**Sifone universale**  
 Siphon universal  
 Bebedero universal  
 Fontaine Universel



**Art. 285**

cc. 400  
**Sifone Livorno**  
 Livorno siphon  
 Bebedero Livorno  
 Fontaine Livorno

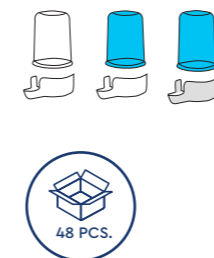

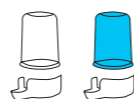

**Art. 018/F**

cc. 70  
**Beverino corto fumè**  
 Short brown siphon  
 Bebedero corto fumé  
 Fontaine court fumé



**Art. 018**

cc. 70  
**Beverino corto**  
 Short siphon  
 Bebedero corto  
 Fontaine court

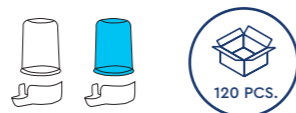

**Art. 068**

cc. 260  
**Sifone Reggio**  
 Reggio siphon  
 Bebedero Reggio  
 Fontaine Reggio

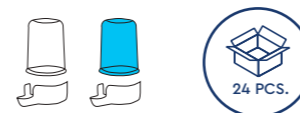

**Art. 060/A**

cc. 400  
**Sifone Lucca con anello**  
 Lucca siphon with ring  
 Bebedero Lucca con anilla  
 Fontaine Lucca avec anneau

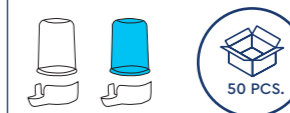

**Art. 038**

cc. 90  
**Sifone lungo**  
 Long siphon  
 Bebedero largo  
 Fontaine long

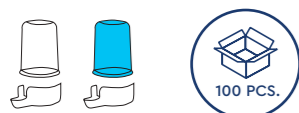

**Art. 087**

cc. 80  
**Sifone banana**  
 Banana-shaped siphon  
 Bebedero banana  
 Fontaine banane

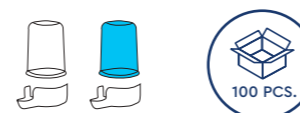

**Art. 395**

**Anello per beverini cc 400**  
 Ring for drinkers cc 400  
 Annilla para bebederos cc 400  
 Anneau pour abreuvoir cc 400



**Art. 034**

cc. 200  
**Sifone Firenze**  
 Firenze siphon  
 Bebedero Floren-  
 cia  
 Fontaine Florence



**Art. 134**

cc. 200  
**Sifone Firenze lusso**  
 Firenze luxury siphon  
 Bebedero Floren-  
 cia lujo  
 Fontaine Florence luxe





BEVERINO A GOCCIA - DROP DRINKER - BEBEDERO A GOTA - FONTAINE AVEC GOUTTE



**BEVERINO CON SFERE**  
SIPHON WITH SPHERES  
BEBEDERO CON BOLAS  
FONTAINE AVEC SPHERE



**BEVERINO SENZA SFERE**  
SIPHON WITHOUT SPHERES  
BEBEDERO SIN BOLAS  
FONTAINE SANS SPHERE

**Art. 361**



**Sifone Revolution cc 72**  
Revolution siphon cc 72  
Bebedero Revolution cc 72  
Fontaine Revolution cc 72



**Art. 362**



**Sifone Revolution cc 105**  
Revolution siphon cc 105  
Bebedero Revolution cc 105  
Fontaine Revolution cc 105



**Art. 363**



**Sifone Revolution cc 140**  
Revolution siphon cc 140  
Bebedero Revolution cc 140  
Fontaine Revolution cc 140



**Art. 364**



**Sifone Revolution cc 200**  
Revolution siphon cc 200  
Bebedero Revolution cc 200  
Fontaine Revolution cc 200



**Art. 365**



**Sifone Revolution cc 260**  
Revolution siphon cc 260  
Bebedero Revolution cc 260  
Fontaine Revolution cc 260



**Art. 366**



**Sifone Revolution cc 400**  
Revolution siphon cc 400  
Bebedero Revolution cc 400  
Fontaine Revolution cc 400

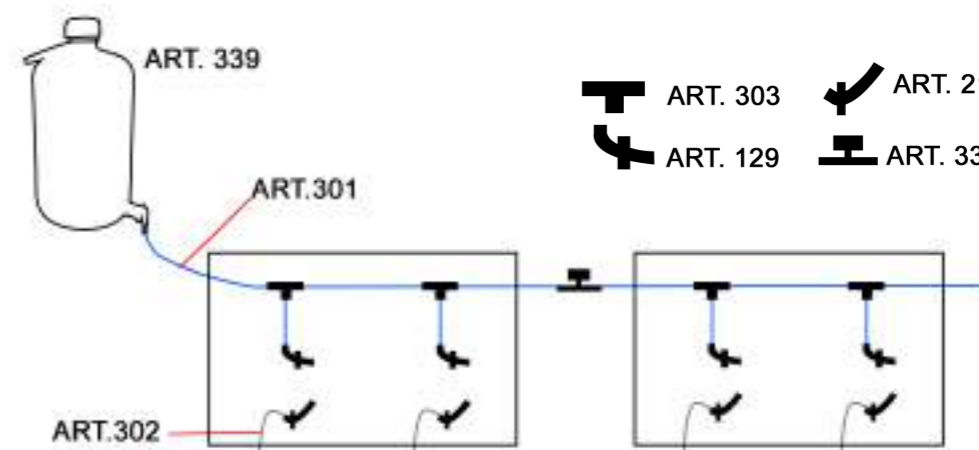

**Art. 129**



**Erogatore magic**  
Magic dispenser  
Dispensador magic  
Distributeur Magique



**Art. 219**



— cm. 6 x 2 x 2h  
**Salva-goccia per Art. 129**  
Drop-saver for Art. 129  
Salva-gota para Art. 129  
Salve-goutte pour Art. 129



**Art. 301**



**Tubo diam. int. 5 per art. 129**  
Tube diameter int. 5 for art. 129  
Tubo diámetro int. 5 para art. 129  
Tube diámetro int. 5 pour art. 129



**Art. 302**



**Tubo diam. int. 8 per art. 219**  
Tube diameter int. 8 for art. 219  
Tubo diámetro int. 8 art. 219  
Tube diámetro int. 8 pour art. 219



**Art. 303**



**Raccordo a "T" per tubo art. 301**  
"T" Connection for tube art. 301  
Conector "T" para tubo art. 301  
Raccord "T" pour tube art. 301



**Art. 338**



**Rubinetto per tubo art. 301**  
Tap for tube art. 301  
Grifo para tubo art. 301  
Robinet pour tube art. 301



**Art. 339**



**Serbatoio per impianto a goccia**  
Tank for drop system  
Tanque para sistema de gota  
Réservoir pour système goutte



LT. 10

**Art. 310**

cc. 500 – cm. 9 × 9 × 10h  
**Beverino Capri**  
 Capri dispenser  
 Bebedero Capri  
 Fontaine Capri



**Art. 170**

cc. 500 – cm. 9 × 9 × 10h  
**Beverino Aves**  
 Aves dispenser  
 Bebedero Aves  
 Fontaine Aves



**Art. 311**

cc. 1000 – cm. 9 × 9 × 18h  
**Beverino Giglio**  
 Giglio dispenser  
 Bebedero Giglio  
 Fontaine Giglio



**Art. 171**

cc. 1000 – cm. 9 × 9 × 18h  
**Beverino Aves**  
 Aves dispenser  
 Bebedero Aves  
 Fontaine Aves



**Art. 130**

cc. 130  
**Beverino magic**  
 Magic drinker  
 Bebedero magic  
 Fontaine magique



**Art. 321**

cc. 400  
**Sifone Bari**  
 Bari siphon  
 Bebedero Bari  
 Fontaine Bari

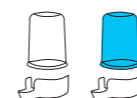

**Art. 066**

cc. 400  
**Sifone Napoli**  
 Napoli siphon  
 Bebedero Napoles  
 Fontaine Napoli

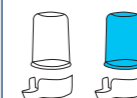

**Art. 065**

cc. 215  
**Sifone mang. pappagalli**  
 Feeder and siphon for parrot  
 Comedero bebedero papa-  
 gayo  
 Siphon mangeoire perroquet



**Art. 253**

— cm. 9 × 9 × 6,5h  
**Mangiatoia "Ara" piccola**  
 "Ara" small Feeder  
 Comodero "Ara" pequeño  
 Mangeoire "Ara" petit



**Art. 254**

— cm. 12 × 12 × 6,5h  
**Mangiatoia "Ara" media**  
 "Ara" medium Feeder  
 Comodero "Ara" mediano  
 Mangeoire "Ara" moyen





**Art. 058**

cc. 1500  
**Abbeveratoio per polli**  
 Water dispenser for chicken  
 Abrevadero para pollitos  
 Abreuvoir pour poulet

**Art. 186**

— cm. 8 × 5  
**Porta**  
 Door  
 Puerta  
 Porte



**MOLLA NON INCLUSA**  
**SPRING NOT INCLUDED**

**Art. 147**

— cm. 8 × 4,5 × 7,5h  
**Mangiatoia "lusso"**  
 "Lusso" feeder  
 Comedero "Lujo"  
 Mangeoire Luxe

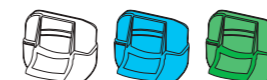
**Art. 160**

— cm. 8 × 4,5 × 7,5h  
**Mangiatoia Milano**  
 Milano feeder  
 Comedero Milano  
 Mangeoire Milano

**Art. 185**

— cm. 7,5 × 5 × 8h  
**Mangiatoia Hasselt**  
 Hasselt feeder  
 Comodero Hasselt  
 Mangeoire Hasselt

**Art. 335**

— cm. 7,3 × 8 × 7,5h  
**Mangiatoia Amsterdam**  
 Amsterdam Feeder  
 Comedero Amsterdam  
 Mangeoire Amsterdam

**Art. 024**

— cm. 7 × 4 × 8h  
**Mangiatoia esterna**  
 External feeder  
 Comedero externo  
 Mangeoire Exterieur

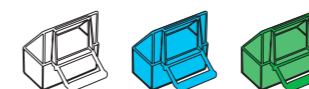
**Art. 232**

— cm. 7 × 4 × 8h  
**Mangiatoia interna con ganci**  
 Internal feeder with hooks  
 Comedero interno con gan-  
 chos  
 Mangeoire interieur avec  
 crochet

**Art. 199**

— cm. 7,5 × 5 × 8h  
**Mangiatoia Piacenza**  
 Piacenza Feeder  
 Comodero Piacenza  
 Mangeoire Piacenza

**Art. 017**

— cm. 7 × 4 × 7h  
**Mangiatoia Napoli**  
 Napoli feeder  
 Comedero Napoles  
 Mangeoire Napoli

**Art. 103**

— cm. 6,5 × 4 × 7,5h  
**Mangiatoia Spagna 2000**  
 Spagna 2000 feeder  
 Comedero España 2000  
 Mangeoire Espagne 2000

**Art. 105**

— cm. 6,5 × 4 × 7,5h  
**Mangiatoia Italia 2000**  
 Italia 2000 feeder  
 Comedero Italia 2000  
 Mangeoire Italia 2000





**Art. 028**



— cm. 6 × 4 × 5,3h  
**Mangiatoia mezzaluna**  
 Half moon shaped feeder  
 Comedero media luna  
 Mangeoire demi-lune



**Art. 035**



— cm. 6 × 4 × 5,3h  
**Mangiatoia mezzaluna ganci**  
 Half moon shaped feeder with hooks  
 Comedero media luna con gancho  
 Mangeoire demi-lune avec crochet



**Art. 336**



— cm. 6,4 × 4,5  
**Coperchio per mangiatoia mezzaluna**  
 Cover for half moon shaped feeder  
 Tapa para comedero media luna  
 Couvercle pour mangeoire demi-lune



**Art. 012**



— cm. 6 × 3,4 × 3,2h  
**Mangiatoia att. dir. piccola**  
 Small feeder with direct connection  
 Comedero pequeño enganche directo  
 Petit mangeoire connexion directe



**Art. 013**



— cm. 6 × 4 × 4,4h  
**Mangiatoia attacco diretto grande**  
 Big feeder with direct connection  
 Comedero grande enganche directo  
 Mangeoire grand connexion directe



**MANGIATOIA  
 Componibile  
 RECUPERA**



**Art. 430**

— cm. 12 × 11 × 16,5h  
**Mangiatoia Recupera**  
 Recupera Feeder  
 Comedero Recupera  
 Mangeoire Recupera

170 Gr



**DIMENSIONI DELLA PORTA MINIME:**  
 MINIMUM DIMENSION OF THE  
 DOOR:

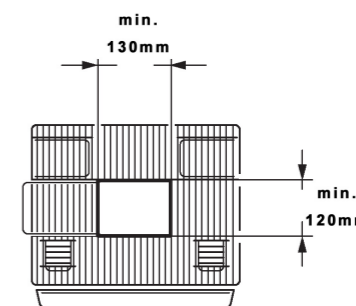



**Art. 433**

**ADATTA A PASTONCINI SECCHI  
E MANGIME COMPOSTO**

- cm. 8 × 10 × 13,5h  
**Mangiatoia Unika**  
Unika feeder  
Comedero Unika  
Mangeoire Unika

KG. 0,160



**RIDUZIONI INCLUSE**  
REDUCTIONS  
INCLUDED



**Art. 323/G**

**Adattatore universale per Mangiatoia Eclissi**  
Universal adapter for Eclipse Feeder  
Adaptador universal para comedero Eclipse  
Adaptateur universel pour mangeoire Eclipse

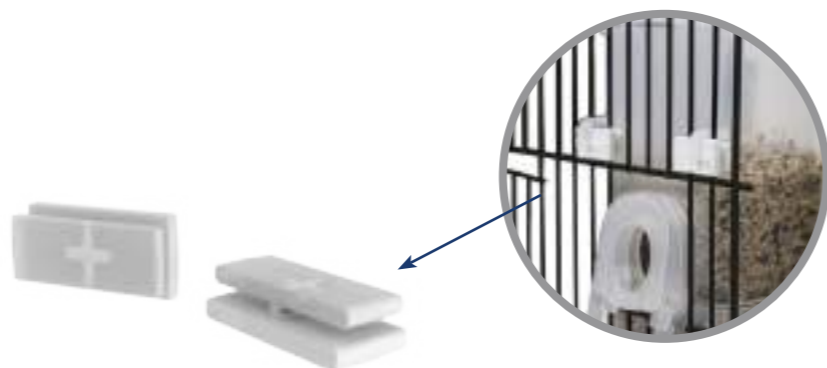

**Art. 323/I**

**Supporti per attacco interno gabbia per Mangiatoia Eclissi**  
Cage's internal attachment for Eclipse Feeder  
Suporte para ataque interno jaula para comedero Eclipse  
Soutien d'attaque a l'interieure cage pour mangeoire Eclipse



**LA NUOVA MANGIATOIA ANTISPRECO RIVOLUZIONARIA**  
THE NEW REVOLUTIONARY NO-WASTE FEEDER  
EL NUEVO COMEDERO REVOLUCIONARIO ANTI-DERROCE  
LE NOUVEAU REVOLUTIONNAIRE MANGEOIRE ANTI-GASPILLAGE

**Art. 323**

- cm. 8 × 10 × 13,5h  
**Mangiatoia Eclissi**  
Eclipse feeder  
Comedero Eclipse  
Mangeoire Eclipse

KG. 0,240



**ADATTATORE 323/G GIÀ INCLUSO**  
ADAPTER 323/G INCLUDED  
ADAPTADOR 323/G INCLUIDO  
ADAPTATEUR 323/G INCLUS

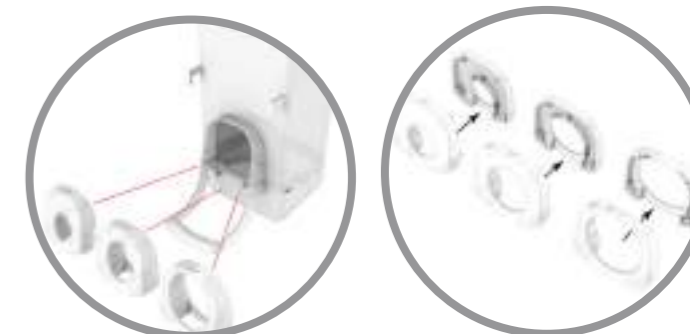

SENZA PORTINA

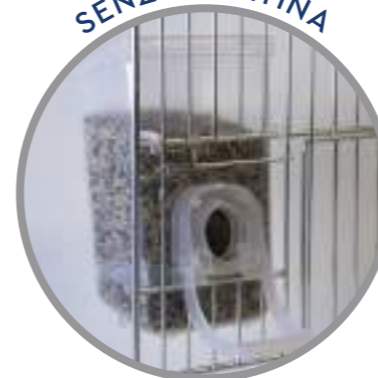

PORTINA MONTATA AL CONTRARIO



PORTINA PIEGATA



# MANGIATOIA REFILL

## Art. 448

- cm.7,5 × 10 × 7,5  
Mangiatoia Refill  
Refill feeder  
Comedero Refill  
Mangeoire Refill

GR. 48 -> 80



## Art. 449

- cm.7,5 × 10 × 7,5  
Mangiatoia Refill  
Refill feeder  
Comedero Refill  
Mangeoire Refill

VERSIONE PER  
GABBIE SPAGNOLE



## Art. 117

- cm. 14 × 10 × 18h  
Mangiatoia economy plus  
Economy plus feeder  
Comedero economy plus  
Mangeoire economique plus



KG. 1

## Art. 169

- cm. 10 × 9 × 15,5h  
Mangiatoia economy Diamant  
Diamant economy feeder  
Comedero economy Diamant  
Mangeoire economique Dia-  
mant



KG. 0,250

## Art. 155

- cm. 14 × 10 × 21h  
Mangiatoia economy dispenser  
Economy feeder dispenser  
Comedero economy dispenser  
Mangeoire economique dispenser



KG. 1

## Art. 115

— cm. 8 × 7 × 16h  
Mangiatoia economy  
Economy feeder  
Comedero economy  
Mangeoire economique



KG. 0,250



KG. 0,250

## Art. 115/A

— cm. 8 × 7 × 16h  
Mangiatoia economy  
Economy feeder  
Comedero economy  
Mangeoire economique



## Art. 116

— cm. 8 × 7 × 16h  
Mangiatoia economy  
Economy feeder  
Comedero economy  
Mangeoire economique



KG. 0,250



KG. 0,250

## Art. 116/A

— cm. 8 × 7 × 16h  
Mangiatoia economy  
Economy feeder  
Comedero economy  
Mangeoire economique





**Art. 022**

— cm. 8 × 4 × 3h  
**Mangiatoia piccola c/ferri**  
 Small feeder with irons  
 Comedero pequeño con gancho  
 Mangeoire petit avec crochet

**Art. 022/G**

— cm. 8 × 4 × 3h  
**Mang. piccola c/ferri con griglia**  
 Small feeder with irons and grid  
 Comedero pequeño c/alambres y huella  
 Mangeoire petit avec crochet et grille

**Art. 125**

— cm. 8 × 4 × 3h  
**Mangiatoia piccola g/plastica**  
 Small feeder with plastic hooks  
 Comedero pequeño con ganchos plástico  
 Mangeoire petit avec crochet de plastique

**Art. 045**

— cm. 10,5 × 5 × 3,5h  
**Mangiatoia media c/ferri**  
 Medium feeder with irons  
 Comedero mediano con alambres  
 Moyenne mangeoire avec fers

**Art. 053**

— cm. 9 × 5 × 4,4h  
**Mangiatoia Parma**  
 Parma feeder  
 Comedero Parma  
 Mangeoire Parma

**Art. 054**

— cm. 9 × 5 × 4,4h  
**Mangiatoia Parma c/ferri**  
 Parma feeder with irons  
 Comedero Parma con alambres  
 Mangeoire Parma avec crochet en fer

**Art. 173**

— cm. 10,5 × 5,5 × 5h  
**Mangiatoia Dalia**  
 Dalia feeder  
 Comedero Dalia  
 Mangeoire Dalia

**ORA CON GRIGLIA!****Art. 172**

— cm. 10,5 × 5,5 × 5h  
**Mangiatoia Ines**  
 Ines feeder  
 Comedero Ines  
 Mangeoire Ines

**Art. 127**

— cm. 9 × 7 × 6,5h  
**Mangiatoia pappagallo g/plastica**  
 Parrot feeder with plastic hooks  
 Comedero papagayo con ganchos plástico  
 Mangeoire perroquet avec crochet de plastique

**Art. 015**

— cm. 9 × 7 × 6,5h  
**Mangiatoia pappagallo c/ferri**  
 Parrot feeder with irons  
 Comedero papagayo con alambres  
 Mangeoire perroquet avec crochet

**Art. 043**

— cm. 10 × 4,5 × 7,5 h  
**Mangiatoia pappagallo con alette**  
 Parrot feeder with wings  
 Comedero para papagayo con alas  
 Mangeoire pour perroquet avec ailes



**Art. 313**

— cm. 7,5 × 5,5 × 4h

**Mangiatoia Olanda c/ganci plastica**

Netherlands Feeder w/plastic hooks  
Comedero Holanda c/ganchos plastico  
Mangeoire Hollande avec crochet plastique

**Art. 320**

— cm. 7,5 × 5,5 × 0,5h

**Antispreco per art. 313/314**

Non-waste cover for art. 313/314  
Anti-derroche art. 313/314  
Anti-gaspillage art. 313/314

**Art. 314**

— cm. 7,5 × 5,5 × 4h

**Mangiatoia Olanda c/ganci in ferro**

Netherlands Feeder w/iron hooks  
Comedero Holanda c/ganchos hierro  
Mangeoire Hollande avec crochet de fer

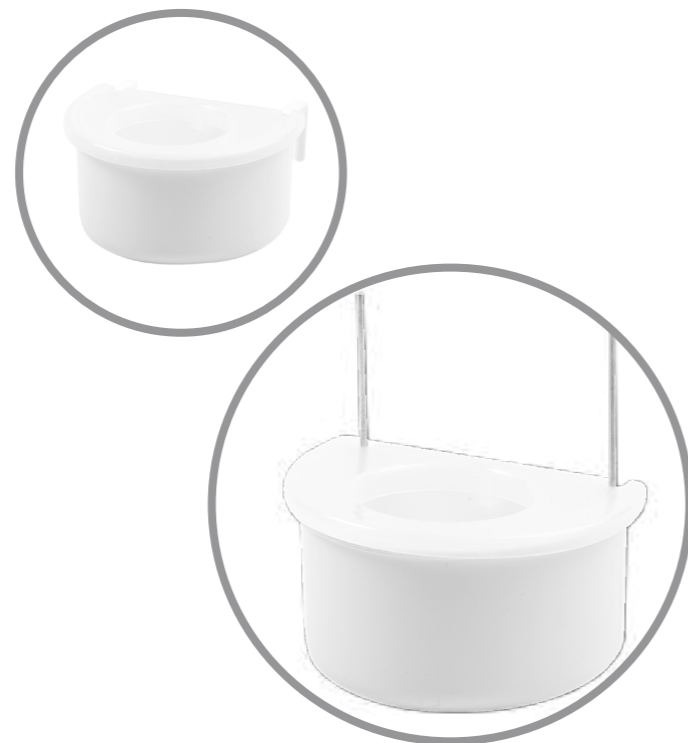
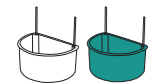
**Art. 324**

— cm. 7 × 7 × 3h

**Mangiatoia per svezzamento**

Weaning feeder  
Comedero para destete  
Mangeoire pour sevrage

**Art. 003**

— cm. 18 × 4 × 3h

**Mangiatoia ganci plastica**

Feeders with plastic hooks  
Comedero gancho plastico  
Mangeoire avec crochet plastique

**Art. 025/G**

— cm. 20 × 6 × 4h

**Mangiatoia universale con griglia**

Universal feeder with grid  
Comedero universal con rejilla  
Mangeoire universel avec grille

**Art. 051**

— cm. 30 × 5,5 × 4h

**Mangiatoia Reggio**

Reggio feeder  
Comedero Reggio  
Mangeoire Reggio

**Art. 052**

— cm. 30 × 5,5 × 4h

**Mangiatoia Reggio c/ferri**

Reggio feeder with irons  
Comedero Reggio con alambres  
Mangeoire Reggio avec crochet

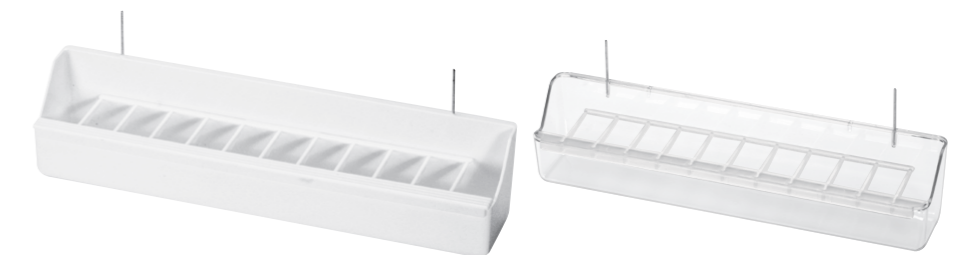
**Art. 100**

— cm. 39 × 5,5 × 6,5h

**Mangiatoia per voliera trasparente c/ferri**

Transparent aviary feeder with irons  
Comedero transp. para voladora con alambre  
Mangeoire transparent pour voliere

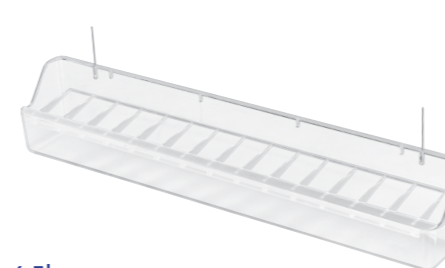
**Art. 101**

— cm. 39 × 5,5 × 6,5h

**Mangiatoia per voliera bianca c/f**

White aviary feeder with irons  
Comedero bianco para voladora con alambre  
Mangeoire blanc pour voliere avec crochet





**Art. 099**

— cm. 39 × 5,5 × 6,5h  
**Mangiatoia per voliera trasparente**  
 Transparent aviary feeder  
 Comedero transp. para voladora  
 Mangeoire transparent pour voliere

**Art. 098**

— cm. 39 × 5,5 × 6,5h  
**Mangiatoia per voliera bianca**  
 White aviary feeder  
 Comedero blanco para voladora  
 Mangeoire blanc pour voliere

**Art. 255**

— cm. 39 × 5,5 × 6,5h  
**Mangiatoia multipla**  
 Multiple feeder  
 Comedero múltiples  
 Mangeoire Multiple

**Art. 190**

— cm. 23 × 7 × 7,5h  
**Mangiatoia Toledo**  
 Toledo Feeder  
 Comedero Toledo  
 Mangeoire Toledo

**Art. 005**

— cm. 31 × 14 × 15h  
**Mangiatoia colombi griglia plastica**  
 Pigeon feeder plastic grid  
 Comedero paloma rejilla plastica  
 Mangeoire pigeons a/grille de plastique

**Art. 006**

— cm. 31 × 14 × 13h  
**Mangiatoia colombi griglia ferro**  
 Pigeon feeder iron grid  
 Comedero paloma rejilla hierro  
 Mangeoire Pigeons a/grille de fer

**Art. 071**

ø cm. 7 × 3,5h  
**Mangiatoia girasole**  
 Sunflower feeder  
 Comedero Girasol  
 Mangeoire Tournesol

**Art. 073**

ø cm. 7 × 3,5h  
**Mangiatoia girasole c/base**  
 Sunflower feeder with base  
 Comedero Girasol con base  
 Mangeoire Tournesol avec base

**Art. 072**

— cm. 7 × 12 × 3,5h  
**Mangiatoia ovale**  
 Oval feeder  
 Comedero Ovalado  
 Mangeoire Ovale

**Art. 119**

— cm. 7 × 12 × 3,5h  
**Mangiatoia Titti**  
 Titti feeder  
 Comedero Titti  
 Mangeoire Titti

**Art. 094**

ø cm. 4,5 × 3,5h  
**Portapastoncino lusso**  
 Luxury mash feeder  
 Portapasta lujo  
 Port pâtée

**Art. 094/A**

ø cm. 4,5 × 4,6h  
**Portapastoncino lusso alto**  
 Luxury high mash feeder  
 Portapasta lujo alto  
 Port pâtée luxe haut

**Art. 322**

ø cm. 2,5 × 2,7 h  
**Porta Sali Valencia**  
 Cup for salt Valencia  
 Porta sales Valencia  
 Port sels Valencia

**Art. 041**

ø cm. 3,5 × 3h  
**Portasali**  
 Cup for salt  
 Portasales  
 Port Sels



**Art. 069**

— **cm. 4 × 3,5h**  
**Portauovo**  
 Egg holder  
 Portahuevo  
 Port Oeuf

**Art. 070**

— **cm. 9 × 6 × 2h**  
**Portabiscotto**  
 Biscuit holder  
 Portabizcocho  
 Port Biscuit

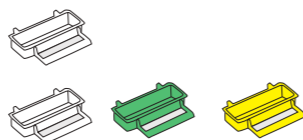
**Art. 049**

— **cm. 13 × 11 × 13h**  
**Bagno Reggio**  
 Reggio bath  
 Bañera Reggio  
 Baignoire Reggio

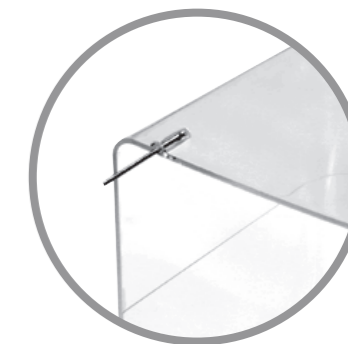
**Art. 057**

— **cm. 6 × 2 × 2h**  
**Portamedicinali**  
 Medicine dispenser  
 Porta medicamentos  
 Port medicament

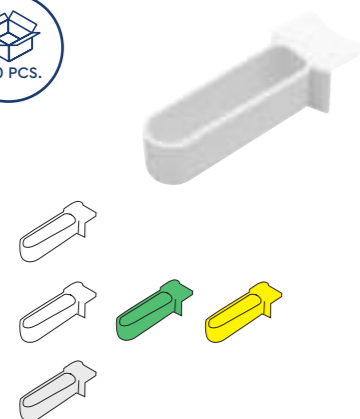
**Art. 122**

— **cm. 7,5 × 3 × 6h**  
**Porta verdura e juta**  
 Vegetables/jute holder  
 Porta verdura y portajuta  
 Port legume et Jute

**Art. 318**

— **cm. 13 × 11 × 13h**  
**Bagno Esterno con ganci in plastica**  
 External Bath with plastic hooks  
 Bañera Externa con ganchos en plastica  
 Baignoire exterieur avec crochet en plastique

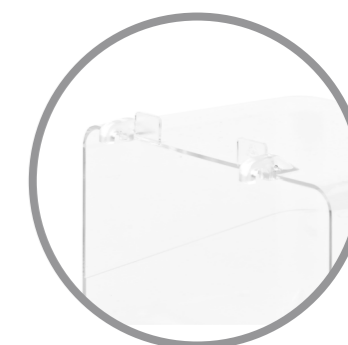
**Art. 440**

— **cm. 8 × 2 × 1,8h**  
**Portamedicinali Vitality**  
 Medicine dispenser Vitality  
 Porta Medicamentos Vitality  
 Port medicament Vitality



**FACILE DA PULIRE!**  
**EASY TO CLEAN!**

**Art. 142**

**cm. 5 × 3 × 1,5h**  
**Pinza universale**  
 Universal holder  
 Pinza universal  
 Pince Universel

**Art. 007**

**cm. 7 × 3 × 1,5h**  
**Molletta gancio**  
 Peg hook  
 Pinza sujetaverduras plastico  
 Pince-crochet

**Art. 046**

— **cm. 13 × 8 × 4h**  
**Vaschetta bagno interna**  
 Internal bathtub  
 Bañera interna  
 Baignoire interieur

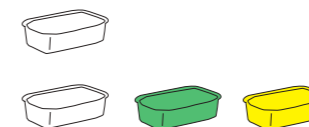
**Art. 074**

— **cm. 13 × 13 × 13h**  
**Bagno esterno lux**  
 Lux external bath  
 Bañera externa lujo  
 Baignoire exterieur luxe

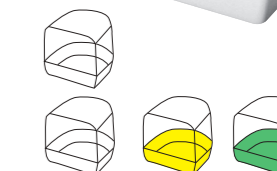
**Art. 033**

**Portaseppia g/plastica**  
 Sepie holder with plastic hooks  
 Portasepia con ganchos plastico  
 Port Seiche avec crochet

**Art. 082**

**Portaseppia**  
 Sepie holder  
 Portasepia  
 Port Seiche

**Art. 435**

— **cm. 11 × 11 × 12h**  
**Bagno esterno Garda**  
 External Bath Garda  
 Bañera externa Garda  
 Baignoire exterieur Garda





**Art.441W**



— cm. 24 × 18 × 16h  
**Bagno esterno Braies**  
 External Bathtub Braies  
 Bañera externa Braies  
 Baignoire extérieur Braies



FONDO BIANCO  
 WHITE BOTTOM

**Art.441T**



— cm. 24 × 18 × 16h  
**Bagno esterno Braies**  
 External Bathtub Braies  
 Bañera externa Braies  
 Baignoire extérieur Braies



FONDO TRASPARENTE  
 CLEAR BOTTOM

**Art. 438W**



— cm. 24 × 17 × 18h  
**Bagno esterno Como**  
 External Bathtub Como  
 Bañera externa Como  
 Baignoire extérieur Como



**Art. 438B**



— cm. 24 × 17 × 18h  
**Bagno esterno Como**  
 External Bathtub Como  
 Bañera externa Como  
 Baignoire extérieur Como



**Art. 223**



— cm. 12,5 × 18 × 16,5h  
**Nido per cardinalini ø 8**  
 Nest for Cardinals ø 8  
 Nido para Cardenales ø 8  
 Nid pour Cardinal ø 8  
 Ø8



CIOTOLA NIDO ESTRAIBILE



**Art. 181**

— cm. 12,5 × 18 × 16,5h  
**Nido Samsara ø 10**  
 Samsara nest ø 10  
 Nido Samsara ø 10  
 Nid Samsara ø 10  
 Ø10



**Art. 437**

— cm. 11 × 12 × 14,5h  
**Nido Easy**  
 Easy nest  
 Nido Easy  
 Nid Easy



**Art. 379**



**Scheda cova per nido art. 181/223/59/374**  
 Breeding cage for nest art. 181/223/59/374  
 Tarjeta cova para nido art.181/223/59/374  
 Carte couvées pour nid art.  
 181/223/59/374



**Art. 059**

— cm. 12 × 12 × 17h  
**Nido esterno lusso**  
 External luxury nest  
 Nido externo lujo  
 Nid exterieur luxe

Ø10

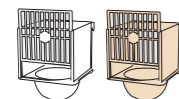

**Art. 059/V**

— cm. 12 × 12 × 17h  
**Nido esterno lusso**  
 External luxury nest  
 Nido externo lujo  
 Nid exterieur luxe

Ø10



**Art. 056**

— cm. 10 × 11 × 16h  
**Nido esterno ferro/plastica**  
 Iron/plastic external nest  
 Nido externo hierro y plastico  
 Nid externe fer/plastique

Ø10



**Art. 039**

**Nido interno**  
 Internal nest  
 Nido interno  
 Nid interne

Ø10



**Art. 008**

**Nido piccolo**  
 Small nest  
 Nido pequeño  
 Petit nid

Ø9



**Art. 325**

**Nido Medio**  
 Medium Nest  
 Nido mediano  
 Nid moyen

Ø11



**Art. 009**

**Nido grande**  
 Large nest  
 Nido grande  
 Grand nid

Ø12



**Art. 376**

**Nido interno in plastica Relax**  
 Internal plastic nest Relax  
 Nido interno en plastico Relax  
 Nid interieur en plastique Relax

Ø10



**Art. 382**

**Fondello in gommapiuma**  
 Foam-rubber pad  
 Fondo para nido en gomaespuma  
 Fond nid en mousse

Ø12



**Art. 381**

**Nido in gommapiuma**  
 Foam-rubber nest  
 Nido de gomaespuma  
 Nid en mousse

Ø10



**Art. 026**

**Portanido in ferro**  
 Iron nest holder  
 Portanido hierro  
 Porte nid en fer

Ø10



**Art. 182**

**Ciotola nido**  
 Nest cup  
 Cazoleta nido  
 Bol nid

Ø10



**Art. 394**

**Portanido in ferro**  
 Iron nest holder  
 Portanido hierro  
 Porte nid en fer

Ø8



**Art. 224**

**Ciotola nido**  
 Nest bowl  
 Cazoleta nido  
 Bol nid

Ø8





- PERFETTO PER:
- ONDULATO
  - NEOPSEPHOTUS
  - AGAPORNIS
  - PSEPHOTUS



## NIDO PARADISE

Art. 374

— cm. 19,5 × 25 × 27,5h  
 Nido Paradise  
 Paradise Nest  
 Nido Paradise  
 Nid Paradise



FORO Ø 6 CM

COMPATIBILE CON TUTTI I TIPI DI PORTA  
 COMPATIBLE WITH ALL DOORS TYPE



FORO Ø 5 CM

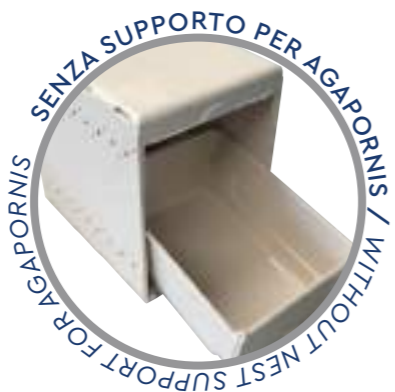

COMPLETAMENTE IN PLASTICA – SMONTABILE E LAVABILE  
 MADE IN PLASTIC – DISMOUNTABLE AND WASHABLE  
 HECHO EN PLASTICO – DESMONTABLE Y LAVABLE  
 FABRIQUE EN PLASTIQUE – DEMONTABLE ET LAVABLE

NIDO PER ONDULATI E  
 PSITACCIDI DI PICCOLA TAGLIA

## NIDO AGAPORNIS

Art. 427

— cm. 16,5 × 20 × 20h  
 Nido Agapornis  
 Agapornis Nest  
 Nido Agapornis  
 Nid Agapornis

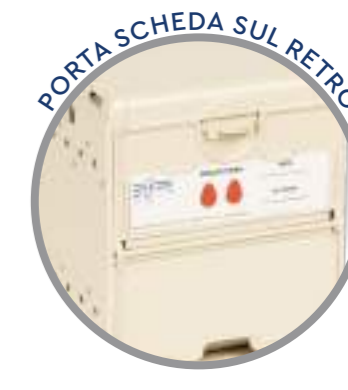

### Art.427T

Coperchio per foro nido Agapornis  
 Hole's cover for nest Agapornis  
 Couvercle pour trou de nid Agapornis  
 Tapa para agujero nido Agapornis



**Art. 432**  
 — cm. 13 × 10 × 10h  
**Nido per esotico**  
 Nest for exotic birds  
 Nido exotico  
 Nid exotique



**Art. 432/G**  
**Ganci per nido esotico**  
 Hooks for exotic nest  
 Ganchos para nido exotico  
 Crochet pour nid exotique



**Art. 299**  
**Nido goccia in vimini**  
 Drop wicker nest  
 Nido gotas en mimbre  
 Nid goutte en osier



**Art. 293**  
**Fondello Nido in Poliestere d. 10**  
 Polyester nest d.10  
 Fondo para nido en poliester d.10  
 Fond nid polyester d. 10





**Art. 084**  
 — cm. 12 × 13 × 16h  
**Nido diamante**  
 Diamond nest  
 Nido diamante  
 Nid Diamant





**Art. 083**  
 — cm. 12 × 13 × 16h  
**Nido perla**  
 Pearl nest  
 Nido perla  
 Nid Perle





**Art. 291**  
**Fondello Nido in juta d. 8 / 10 / 12**  
 Bird nest pad in jute d. 8 / 10 / 12  
 Fondo para nido en yute d. 8 / 10 / 12  
 Fond nid en jute d. 8 / 10 / 12

**Art. 292**  
**Fondello Nido in juta - cotone d. 8 / 10 / 12**  
 Wicker and pad bird nest d. 8 / 10 / 12  
 Fondo para nido en yute y mimbre d. 8 / 10 / 12  
 Fond nid en jute et coton d. 8 / 10 / 12

**Art. 290/8**  
**Fondello Nido in vimini**  
 Wicker bird nest  
 Fondo para nido en mimbre  
 Fond nid osier

**Art. 290/9**  
**Fondello Nido in vimini**  
 Wicker bird nest  
 Fondo para nido en mimbre  
 Fond nid osier

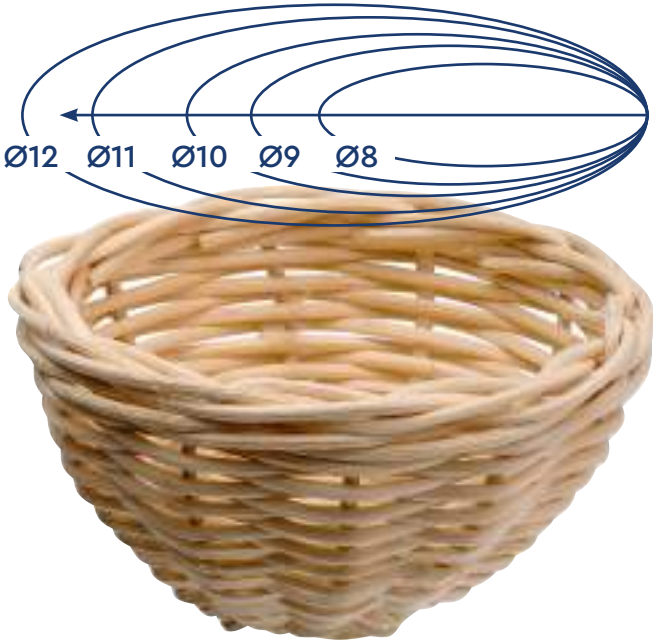

**Art. 290/10**  
**Fondello Nido in vimini**  
 Wicker bird nest  
 Fondo para nido en mimbre  
 Fond nid osier



**Art. 290/11**  
**Fondello Nido in vimini**  
 Wicker bird nest  
 Fondo para nido en mimbre  
 Fond nid osier



**Art. 290/12**  
**Fondello Nido in vimini**  
 Wicker bird nest  
 Fondo para nido en mimbre  
 Fond nid osier



**Art. 290/15**  
**Fondello Nido in vimini**  
 Wicker bird nest  
 Fondo para nido en mimbre  
 Fond nid osier





**Art. 118**

ø 7,5 x 7h  
**Porta Juta**  
 Nesting material holder  
 Porta Juta  
 Ramasseur de Jute



**Art. 118/P**

**Porta Juta pieno**  
 Holder with jute  
 Porta Juta con jute  
 Ramasseur de Jute plein



**Art. 097**

— cm. 6 x 8 X 4h  
**Raccogliore universale**  
 Multi purpose holder  
 Portapelo universal  
 Ramasseur Universel



**Art. 097/P**

**Raccogliore juta pieno**  
 Jute holder full  
 Porta-Juta lleno  
 Ramasseur de Jute plein



**Art. 294**

**Confezione di Juta**  
 Juta's packaging  
 Confeccion de Yute  
 Confection de Jute



**Art. 298**

**Cocco-Sisal-Meliga-Brattea**



**Art. 296**

**Confezione di Filo di Cotone**  
 Cottons's packaging  
 Confeccion de Hilo de coton  
 Confection de Fil de coton



**Art. 297**

**Cocco-Sisal-Juta-Cotone**  
 Cocco-Sisal-Juta-Cotton  
 Cocco-Sisal-Yute-Coton  
 Coque-Sisal-Jute-Coton



**Art. 295**

**Juta-Cotone**  
 Jute-Cotton  
 Yute-Coton  
 Jute-Coton



**Art. 384**

— cm. 12,5 x 10,5 x 1,2 h  
**Portascheda Twister**  
 Card holder "Twister"  
 Portatarjeta "Twister"  
 Porte-carte "Twister"



**IL NUOVO PORTA SCHEDA RIVOLUZIONARIO!**  
 NEW REVOLUTIONARY CARD HOLDER!  
**EL NUEVO PORTA TARJETA REVOLUCIONARIO!**  
 LE NOUVEAU PORTE-CARTE REVOLUTIONNAIRE!

**Art. 001/A**

— cm. 12,5 x 9  
**Scheda a 4 cove**  
 Card for 4 broods  
 Tarjeta para 4 covas  
 Carte pour 4 couvées



**Art. 385**

— ø 4  
**Schedina Twister**  
 "Twister" Card  
 Tarjeta "Twister"  
 Carte "Twister"



**Art. 306/MONO**

**Anelli in plastica monocolore d. 2,8 mm**  
 Monochrome plastic rings d. 2,8 mm  
 Anillas en plástico mono color d. 2,8 mm  
 Anneaux de plastique monochrome 2,8 mm

**Art. 306/MIX**

**Anelli in plastica multicolore d. 2,8 mm**  
 Multicolored plastic rings d. 2,8 mm  
 Anillas en plástico multicolor d. 2,8 mm  
 Anneaux de plastique multicolor 2,8 mm

**Art. 307**

**Anelli "click" in plastica d. 8 / 12 / 16**  
 Plastic "click" rings d. 8 / 12 / 16  
 Anillas abierta en plastica d. 8 / 12 / 16  
 Anneaux de plastique d. 8 / 12 / 16

**Art. 308**

**Anelli in alluminio d. 2,5 / 3 / 4**  
 Aluminium rings d. 2,5 / 3 / 4  
 Anillas en aluminio d. 2,5 / 3 / 4  
 Anneaux de aluminium d. 2,5 / 3 / 4



2,5

3

4

**Art. 308**

**Anelli in alluminio d. 6 / 8 / 10 / 12**  
 Aluminium rings d. 6 / 8 / 10 / 12  
 Anillas en aluminio d. 6 / 8 / 10 / 12  
 Anneaux de aluminium d. 6 / 8 / 10 / 12

**Art. 309**

**Tronchese inox per anellini**  
 Stainless steel nippers for rings  
 Tijeras en acero para anillitas  
 Cutter pour anneaux

**Art. 078**

— cm. 15 x 3 x 1h  
**Pinza Reggio**  
 Reggio pliers  
 Pinza Reggio  
 Pince Reggio

**Art. 010**

ø 1,3 x 1,6h  
**Uova piccole**  
 Small eggs  
 Huevo pequeño  
 Petit Oeufs

**Art. 010/C**

ø 1,3 x 1,6h  
**Uova piccole colorate**  
 Small coloured eggs  
 Huevo pequeño azul-verde  
 Petit Oeufs de couleur

**Art. 011**

ø 3 x 4h  
**Uova per colombi**  
 Pigeons eggs  
 Huevos para palomas  
 Oeufs pour pigeons

**Art. 304**

ø 2 x 2,5h  
**Uova medio Parrocchetto**  
 Medium plastic eggs for parakeets  
 Huevos medianos para pericos  
 Moyen Oeufs pour perroquet

**Art. 305**

ø 2,5 x 3h  
**Uova grandi Parrocchetto**  
 Big plastic eggs for parakeets  
 Huevos grandes para pericos  
 Grand Oeufs pour perroquet





**Art. 036**



— cm. 29,5 × 32 × 1  
**Laterale in plastica per gabbia cova 55**  
*Plastic side for breeding cage 55*  
*Lateral en plastico para jaula de cria 55*  
*Lateral en plastique pour cage d'élevage 55*



**Art. 037/A**



— cm. 54,5 × 6 × 0,5  
**Bandina frontale gabbia cova 55**  
*Drawer's cover for breeding cage 55*  
*Frontal para bandeja jaula de cria 55*  
*Couvercle du tiroir pour cage d'élevage 55*



**Art. 064**



— cm. 54,2 × 30 × 4  
**Fondo gabbia cova 55**  
*Bottom part of breeding cage 55*  
*Bandeja para jaula de cria 55*  
*Tiroir pour cage d'élevage 55*



**GABBIA COVA 58×30 CM**  
**LATERALI IN FERRO**

**Art. 317/B**



cm. 58 × 30 × 39h  
**Gabbia cova plastificata**  
*Plastified breeding cage*  
*Jaula de cria plastificada*  
*Cage de élevage plastifiée*



3 PORTE  
 GRANDI

**Art. 317/Z**



cm. 58 × 30 × 39h  
**Gabbia cova zincata**  
*Breeding galvanized cage*  
*Jaula de cria zincada*  
*Cage de élevage zingué*



3 PORTE  
 GRANDI



SALVA SPAZIO



18 conf.  
 108 gabbie



cm 78 × 60 × 22h  
 22 kg

## GABBIA COVA 58x30 CM LATERALI IN PLASTICA

Art. 326/B



cm. 58 x 30 x 39h  
Gabbia cova plasticata  
Plastified breeding cage  
Jaula de cria plasticada  
Cage de élevage plastifiée



SISTEMA CARTA  
PAPER SYSTEM  
SISTEMA PAPEL  
SYSTEME PAPIER

Art. 326/SC



Gabbia cova  
Breeding cage  
Jaula de cria  
Cage de élevage



Art. 326/Z



cm. 58 x 30 x 39h  
Gabbia cova zincata  
Breeding galvanized cage  
Jaula de cria zincada  
Cage de élevage zingué

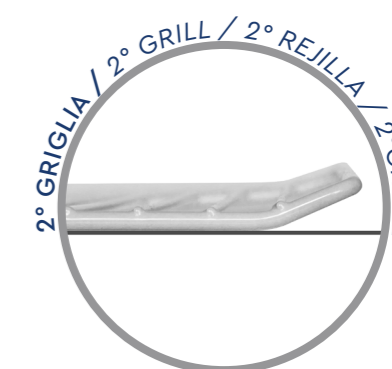
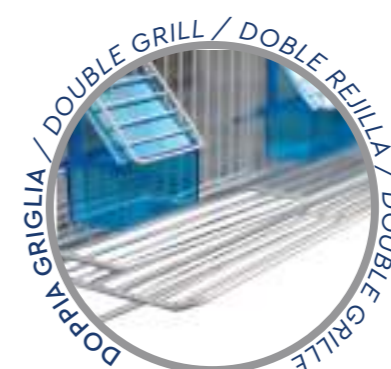

### ACCESSORI COVA 58x30 CM

Art. 375



- cm. 58x37  
Parete retro gabbia cova cm 58  
Back wall for breeding cage cm 58  
Pared trasera para jaula de cria cm 58  
Mur d'arrière pour cage d'élevage cm 58

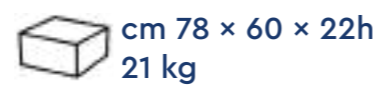
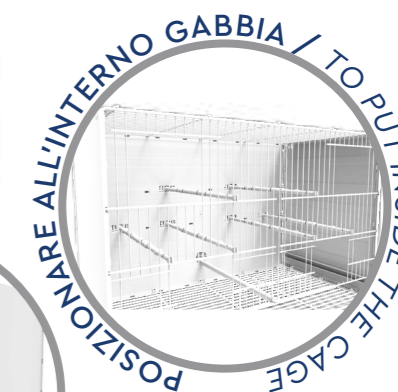



## ACCESSORI COVA 58x30 CM

## Art. 337

**Sistema Voliera**  
 Aviary System  
 Sistema voladora  
 Système Volière

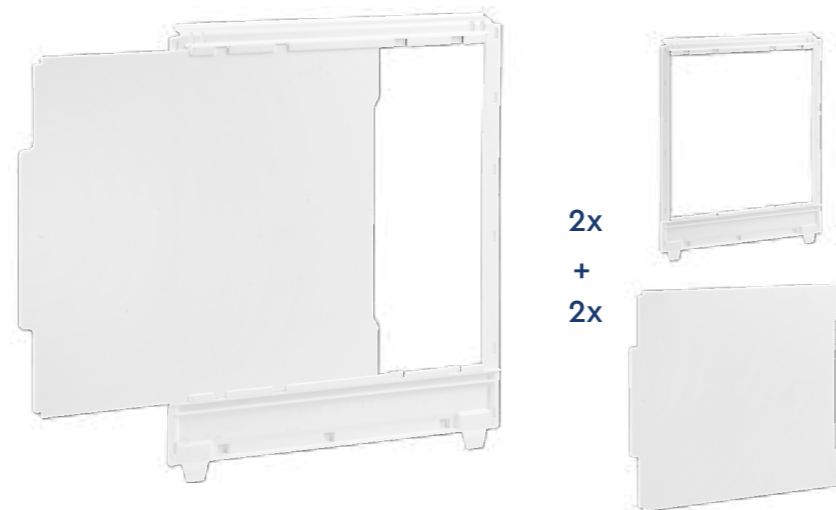

2x  
 +  
 2x

**SISTEMA VOLIERA**  
 AVIARY SYSTEM  
 SISTEMA AVIARIO  
 SYSTEME VOLIERE



## Art. 356



**Gancio per unione gabbie cm 58**  
 Union hook for cage cm 58  
 Gancho de union jaula cm 58  
 Crochet pour union cage cm 58



## Art. 334



**Gancio ferma griglia**  
 Grill's block  
 Bloc du grille  
 Bloque para rejilla



## Art. 327



— cm. 31 × 39 × 2,5  
**Laterale in plastica per gabbia cova 58**  
 Plastic side for breeding cage 58  
 Lateral en plastico para jaula de cria 58  
 Lateral en plastique pour cage d'élevage 58



## Art. 328



— cm. 56,5 × 30 × 3  
**Cassetto per gabbia cova 58**  
 Drawer for breeding cage 58  
 Bandeja jaula de cria 58  
 Tiroir pour cage d'élevage 58



## ACCESSORI COVA 58x30 CM

## Art. 331



**Divisorio chiuso per gabbia cova 58**  
 Closed dividing wall for breeding cage 58  
 Pared divisoria cerrada para jaula de cria 58  
 Cloison ferme pour cage d'élevage 58



## Art. 330



— cm. 32 × 2 × 1  
**Guida per divisorio**  
 Slide guide for dividing wall  
 Guia para pared divisoria  
 Guide pour coison



## Art. 332



**Griglia per gabbia cova 58**  
 Grill for breeding cage 58  
 Rejilla para jaula de cria 58  
 Grille pour cage d'élevage 58

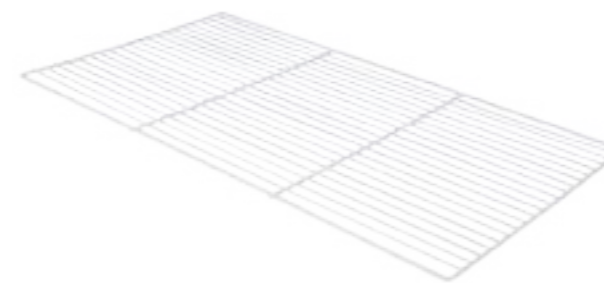

## Art. 333



**Griglia incurvata per gabbia cova 58**  
 Curved grill for breeding cage 58  
 Rejilla incurvada para jaula de cria 58  
 Grille incurvée pour cage d'élevage 58

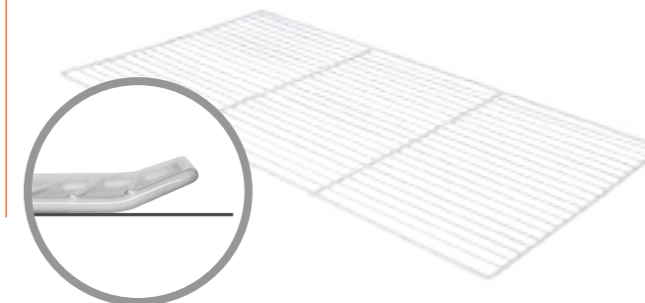

## Art. 350



— cm. 31,6  
**Posatoio per gabbia da cova**  
 Perch for breeding cage  
 Posadero para jaula de cria  
 Perche pour cage d'élevage



**COMPATIBILE CON GABBIE COVA DA 55 CM E 58 CM**  
 COMPATIBLE WITH BREEDING CAGES CM 55 AND CM 58  
 COMPATIBLE CON JAULA DE CRIA CM 55 Y CM 58  
 COMPATIBLE AVEC CAGES D'ELEVAGE 55 CM ET 58

## Art. 424



cm 54 × 27,5  
**Carta bulinata per cova 58**  
 Absorbent paper cage cm 58  
 Carta absorbente jaula cm 58  
 Papier absorbant cage cm 58



**COMPATIBILE CON GABBIE 326 E 317**  
 COMPATIBLE WITH CAGES 326 AND 317  
 COMPATIBLE CON JAULAS 326 Y 317  
 COMPATIBLE AVEC LES CAGES 326 AT 317

## GABBIA COVA DA 60x40 CM FRONTALE PLASTIFICATO

**Art.460**



-cm 61 x 42 x 44h  
**Gabbia cova 60 Taormina**  
 Breeding cage 60 Taormina  
 Jaula de cria 60 Taormina  
 Cage d'élevage 60 Taormina



**RETRO IN PLASTICA**  
 PLASTIC BACK WALL  
 PARED TRASERA EN PLASTICO  
 MUR D'ARRIER EN PLASTIQUE



cm 79 x 47 x 22h  
 8,5 kg

## GABBIA COVA DA 60x40 CM FRONTALE ZINCATO

**Art. 462**



-cm 61 x 42 x 44h  
**Gabbia cova 60 Porto Cervo**  
 Breeding cage 60 Porto Cervo  
 Jaula de cria 60 Porto Cervo  
 Cage d'élevage 60 Porto Cervo



**RETRO IN PLASTICA**  
 PLASTIC BACK WALL  
 PARED TRASERA EN PLASTICO  
 MUR D'ARRIER EN PLASTIQUE



cm 79 x 47 x 22h  
 8,5 kg

**Art. 461**



cm 61 x 42 x 44h  
**Gabbia cova 60 Tropea**  
 Breeding cage 60 Tropea  
 Jaula de cria 60 Tropea  
 Cage d'élevage 60 Tropea

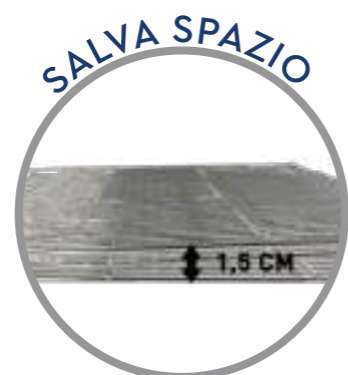
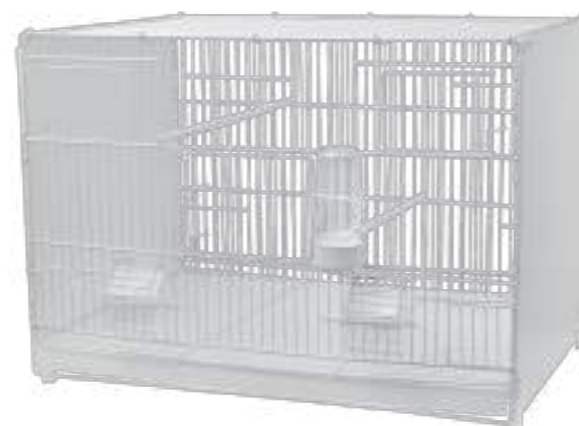

**Art. 463**



-cm 61 x 42 x 44h  
**Gabbia cova 60 Polignano**  
 Breeding cage 60 Polignano  
 Jaula de cria 60 Polignano  
 Cage d'élevage 60 Polignano



**RETRO IN RETE**  
 GRILL BACK WALL  
 PARED TRASERA DE REJILLA  
 MUR D'ARRIER DE GRILLE



## GABBIA COVA DA 90×40 CM FRONTALE PLASTIFICATO

**Art. 420**



cm 91,50 × 42 × 44,5h  
**Gabbia cova 90 Positano**  
 Breeding cage 90 Positano  
 Jaula de cria 90 Positano  
 Cage d'élevage 90 Positano



RETRO IN PLASTICA  
 PLASTIC BACK WALL  
 PARED TRASERA EN PLASTICO  
 MUR D'ARRIER EN PLASTIQUE



28 conf.  
56 gabbie

cm 94 × 48 × 16,5h  
15 kg

**Art. 421**



cm 91,50 × 42 × 44,5h  
**Gabbia cova 90 Portofino**  
 Breeding cage 90 Portofino  
 Jaula de cria 90 Portofino  
 Cage d'élevage 90 Portofino



SALVA SPAZIO



## GABBIA COVA DA 120×40 CM FRONTALE PLASTIFICATO

**Art. 400**



cm 122 × 42 × 44,5h  
**Gabbia cova 120 Cortina**  
 Breeding cage 120 Cortina  
 Jaula de cria 120 Cortina  
 Cage d'élevage 120 Cortina

RETRO IN PLASTICA  
 PLASTIC BACK WALL  
 PARED TRASERA EN PLASTICO  
 MUR D'ARRIER EN PLASTIQUE



22 conf.  
44 gabbie

cm 79 × 47 × 22h  
17 kg

**Art. 401**



cm 122 × 42 × 44,5h  
**Gabbia cova 120 Bormio**  
 Breeding cage 120 Bormio  
 Jaula de cria 120 Bormio  
 Cage d'élevage 120 Bormio

RETRO IN RETE  
 GRILL BACK WALL  
 PARED TRASERA DE REJILLA  
 MUR D'ARRIER DE GRILLE



## GABBIA COVA DA 120×40 CM FRONTALE ZINCATO

**Art. 402**



cm 122 × 42 × 44,5h  
Gabbia cova 120 Sestriere  
Breeding cage 120 Sestriere  
Jaula de cria 120 Sestriere  
Cage d'levage 120 Sestriere



SALVA SPAZIO



22 conf.  
44 gabbie

cm 79 × 47 × 22h  
17 kg

**Art. 403**



cm 122 × 42 × 44,5h  
Gabbia cova 120 Livigno  
Breeding cage 120 Livigno  
Jaula de cria 120 Livigno  
Cage d'levage 120 Livigno

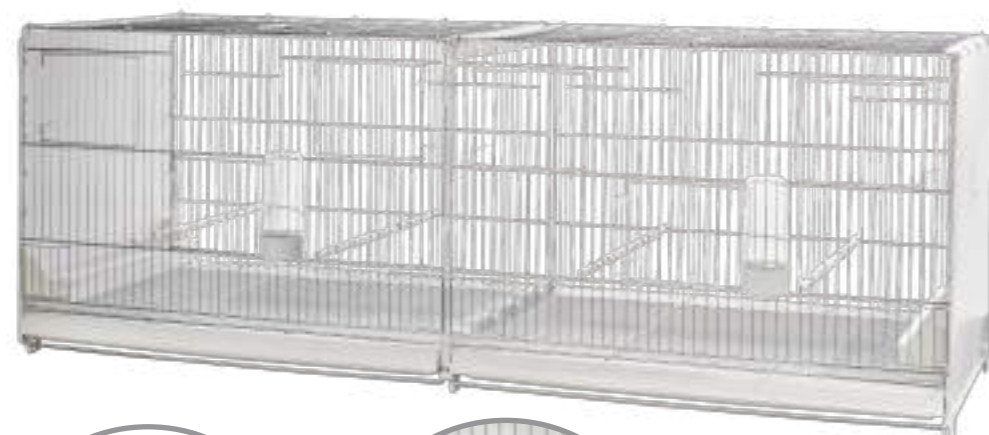

SALVA SPAZIO

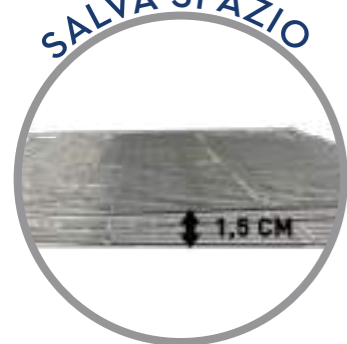

## ACCESSORI COVA 90 e 120 CM

**Art. 396**



cm 59,5 × 42 × 3,5h  
Cassetto gabbia cova 120  
Bottom breeding cage 120  
Bandeja jaula de cria 120  
Tiroir pour cage d'levage 120



**Art. 414**

cm 44 × 42 × 4h  
Cassetto gabbia cova 90  
Drawer for breeding cage 90  
Bandeja jaula de cria 90  
Tiroir pour cage d'levage 90



**Art. 397**



cm 42 × 44,5 × 1,5h  
Laterale in plastica gabbia cova 90 e 120  
Plastic side for breeding cage 90 and 120  
Lateral de plastico jaula de cria 90 y 120  
Lateral en plastique cage d'levage 90 et 120



**Art. 423**

Griglia bianca per gabbia cova 90  
White gril for breeding cage 90  
Rejilla blanca para jaula de cria 90  
Grille blanche pour cage elevage 90

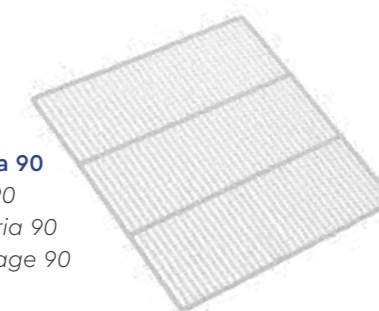

**Art. 404**

Griglia bianca per gabbia cova 120  
White gril for breeding cage 120  
Rejilla blanca para jaula de cria 120  
Grille blanche pour cage elevage 120



**Art. 405**

Griglia zincata per gabbia cova 120  
Metal gril for breeding cage 120  
Rejilla zincada para jaula de cria 120  
Grille zingue pour cage elevage 120



## ACCESSORI COVA 90 e 120 CM

**Art. 411**



cm 41 × 34,5h  
Divisorio in plastica per cova 90 e 120  
Plastic divider breeding cage 90 and 120  
Pared divisoria en plastico jaula 90 y 120  
Cloison ferme pour cage d'levage 90 et 120





**Art. 413**

cm 41 × 34,5h  
**Divisorio in ferro per cova 90 e 120**  
 Iron dividing wall for cage 90 and 120  
 Pared divisoria en hierro para jaula 90 y 120  
 Cloison en fer pour cage 90 et 120

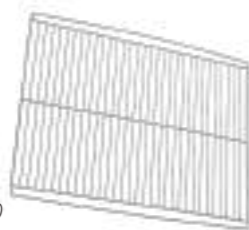
**Art. 442**

cm 41 × 34,5h  
**Divisorio in plastica grigliato**  
 Plastic grill divider  
 Rejilla divisoria en plastico  
 Grille diviseur en plastique

**Art. 416**

cm 44 × 42  
**Parete retro per gabbia 90**  
 Back wall for breeding cage 90  
 Pared trasera para jaula de cria 90  
 Mur d'arriere pour cage d'elevage 90

**Art. 399**

cm 60 × 41,5  
**Parete retro per gabbia 120**  
 Back wall for breeding cage 120  
 Pared trasera para jaula de cria 120  
 Mur d'arriere pour cage d'elevage 120

**Art. 417**

**Kit guide per cova 90**  
 Guides for cage 90  
 Guida para jaula 90  
 Guide pour cage 90

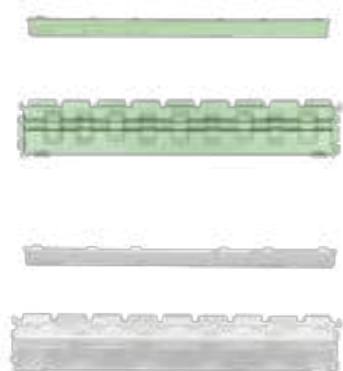
**Art. 398**

**Kit voliera gabbia cova 60/90/120**  
 Aviary kit breeding cage 60/90/120  
 Sistema voladora jaula de cria 60/90/120  
 System voliere cage elevage 60/90/120

**ACCESSORI COVA 90 e 120 CM****Art. 407**

cm 43  
**Posatoio con perno per gabbia 60/90/120**  
 Perch with pin for cage 60/90/120  
 Posadero con punta para jaula 60/90/120  
 Perche avec pointe pour cage 60/90/120



**PER GABBIE CODICE 400/402/420/421**  
 FOR CAGES 400/402/420/421  
 PARA JAULA 400/402/420/421  
 POUR CAGES 400/402/420/421

**Art. 408**

cm 43  
**Posatoio per gabbia 60/90/120**  
 Perch for cage 60/90/120  
 Posadero para jaula 60/90/120  
 Perche pour cage 60/90/120



**PER GABBIE CODICE 401/403**  
 FOR CAGES 401/403  
 PARA JAULA 401/403  
 POUR CAGES 401/403

**Art. 409**

**Maniglia universale**  
 Universal handle  
 Manilla universal  
 Poignee universelle

**Art. 410**

**Porta mangiatoia interno**  
 Internal feeder holder  
 Porta comedero interno  
 Porte mangeoire interieur

**Art. 425**

cm 57 × 38  
**Carta bulinata per cova 120**  
 Absorbent paper cage cm 120  
 Carta assorbente jaula cm 120  
 Papier absorbant cage cm120



COMPATIBILE CON GABBIE 400/401/402/403  
 COMPATIBLE WITH CAGES CODE 400/401/402/403  
 COMPATIBLE CON JAULAS 400/401/402/403  
 COMPATIBLE AVEC LES CAGES 400/401/402/403

**Art. 426**

cm 41 × 38  
**Carta bulinata per cova 90**  
 Absorbent paper cage cm 90  
 Carta assorbente jaula cm 90  
 Papier absorbant cage cm 90



COMPATIBILE CON GABBIE 420/421  
 COMPATIBLE WITH CAGES CODE 420/421  
 COMPATIBLE CON JAULAS 420/421  
 COMPATIBLE AVEC LES CAGES 420/421

**CARRELLI PER GABBIE 60 - 90 - 120 CM**

**Art. 455**

cm 61 x 35 x 36h  
**Carrello 60 per gabbie cova**  
*Trolley 60 for breeding cages*  
*Carro 60 para jaulas de cria*  
*Chariot 60 pour cages d'elevage*



**Art. 429**

cm 92 x 44 x 36h  
**Carrello 90 per gabbie cova**  
*Trolley 90 for breeding cages*  
*Carro 90 para jaulas de cria*  
*Chariot 90 pour cages d'elevage*



**Art. 418**

cm 122,50 x 44 x 36h  
**Carrello 120 per gabbie cova**  
*Trolley 120 for breeding cages*  
*Carro 120 para jaulas de cria*  
*Chariot 120 pour cages d'elevage*



**Art. 419**

cm 182,5 x 44 x 36h  
**Carrello 180 per gabbie cova**  
*Trolley 180 for breeding cages*  
*Carro 180 para jaulas de cria*  
*Chariot 180 pour cages d'elevage*

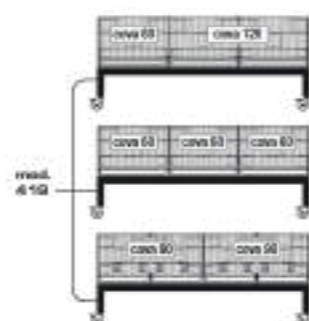

**STRUTTURE GABBIE COVA DA 58 CM**  
**STRUCTURE FOR BREEDING CAGES CM 58**  
**ESTRUCTURAS PARA JAULAS DE CRIA CM 58**  
**STRUCTURE POUR CAGES D'ELEVAGE CM 58**

**SISTEMA CARTA**  
**PAPER SYSTEM - SISTEMA PAPEL - SYSTEME PAPIER**  
**FISSAGGIO A MURO**  
**WALL FASTENING - SE FIJA A LA PARED - FIXATION A MUR**

**Art. 340**

**Struttura per sistema carta 2 x 4**  
*Structure for paper system 2 x 4*  
*Estructura para sistema papel 2 x 4*  
*Structure pour système papier 2 x 4*

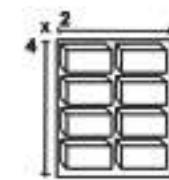

cm. 135 x 41 x 199h



**Art. 341**

**Struttura per sistema carta 4 x 4**  
*Structure for paper system 4 x 4*  
*Estructura para sistema papel 4 x 4*  
*Structure pour système papier 4 x 4*

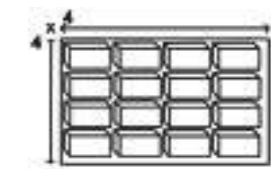

cm. 255 x 41 x 199h



**SISTEMA CON CASSETTO**  
**DRAWER'S SYSTEM - SISTEMA CON BANDEJA - SYSTEM AVEC TIROIR**  
**FISSAGGIO A MURO**  
**WALL FASTENING - SE FIJA A LA PARED - FIXATION A MUR**

**Art. 342**

**Strutt. per sistema cassetto 2 x 4**  
*Struct. for drawer's system 2 x 4*  
*Estructura para sistema bandeja 2 x 4*  
*Structure pour système avec tiroir 2 x4*



**Art. 343**

**Strutt. per sistema cassetto 4 x 4**  
*Struct. for drawer's system 4 x 4*  
*Estructura para sistema bandeja 4 x 4*  
*Structure pour système avec tiroir 4 x4*



**STRUTTURA FRONTE E RETRO**  
**BACK AND FRONT SIDE STRUCTURE**  
**ESTRUCTURA TRASERA Y DELANTERA**  
**STRUCTURE AVANT ET ARRIÈRE**

**SISTEMA CARTA**  
**PAPER SYSTEM - SISTEMA PAPEL - SYSTEME PAPIER**

**Art. 345**

**Struttura doppia per sistema carta 2 x 4**  
*Double structure for paper system 2 x 4*  
*Estructura doble para sistema papel 2 x 4*  
*Structure double pour système papier 2 x4*



**Art. 346**

**Struttura doppia per sistema carta 4 x 4**  
*Double structure for paper system 4 x 4*  
*Estructura doble para sistema papel 4 x 4*  
*Structure double pour système papier 4 x4*



**GABBIE NON INCLUDE**  
**CAGES NOT INCLUDED**

**SISTEMA CON CASSETTO**  
DRAWER'S SYSTEM – SISTEMA CON BANDEJA – SYSTEM AVEC TIROIR

**Art. 347**

Struttura doppia per sistema cassetto 2 x 4  
Double structure for drawer's system 2 x 4  
Estructura doble para sistema bandeja 2 x 4  
Structure double pour système avec tiroir 2 x 4



**Art. 348**

Struttura doppia per sistema cassetto 4 x 4  
Double structure for drawer's system 4 x 4  
Estructura doble para sistema bandeja 4 x 4  
Structure pour système avec tiroir 4 x 4

32 GABBIE



**Art. 349**

- Ø 12 x 33 cm  
Rotolo di carta  
Paper roll  
Rollo de papel  
Rouleau de papier



**Art. 439**

cm 119 X 33 X 36h  
Carrello 120 per gabbie cova cm 58  
Trolley 120 for breeding cages cm 58  
Carro 120 para jaulas de cria cm 58  
Chariot 120 pour cages d'eleavage cm 58



COMPATIBILE CON GABBIE 326  
COMPATIBLE ONLY WITH CAGE 326

**Art. 454**

cm 59 x 33 x 36h  
Carrello 58 per gabbia cova  
Trolley 58 for breeding cage  
Carro 58 para jaulas de cria  
Chariot 58 pour cages d'eleavage



**Art. 344**

Ruote per struttura singola art. 340-342  
Wheels for single structure art. 340-342  
Ruedas estructura individual art. 340-342  
Roues pour structure individuel art. 340-342





## GABBIE DA ESPOSIZIONE EXPOSITION CAGES – JAULAS EXPOSICION – CAGE EXPOSITION

IDEALE PER LE MOSTRE  
PERFECT FOR SHOWS – PERFECTO PARA MUESTRAS – PARFAIT POUR MONTRE



### Art. 315/FB1

cm. 36 × 17 × 30h  
Gabbia espos. 1 porta frontale bianco  
Exposition cage 1 door white frontal  
Jaula exposicion 1 puerta y frontal blanco  
Cage exposition 1 porte frontal blanc

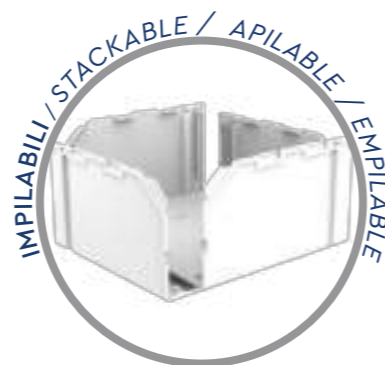

### Art. 315/FN1

cm. 36 × 17 × 30h  
Gabbia espos. 1 porta frontale nero  
Exposition cage 1 door black frontal  
Jaula exposicion 1 puerta y frontal negro  
Cage exposition 1 porte frontal noir



### Art. 315/SP

cm. 36 × 17 × 30h  
Gabbia espos. con foro laterale  
Exposition cage with lateral hole  
Jaula exposicion con agujero lateral  
Cage exposition avec trou lateral



SPECIALE CON  
FORO LATERALE



cm. 58 × 39 × 39h 160 pcs

IDEALE PER LA PREPARAZIONE  
PERFECT FOR PREPARATION – PERFECTO PARA LA PREPARACION – PARFAIT POUR LA PREPARATION



### Art. 315/FN3V

cm. 36 × 17 × 30h  
Gabbia espos. verde 3 porte front. nero  
Green exposition cage 3 door black frontal  
Jaula exposicion verde 3 puertas y frontal negro  
Cage exposition vert 3 portes frontal noir



### Art. 315/FB3

cm. 36 × 17 × 30h  
Gabbia espos. 3 porte frontale bianco  
Exposition cage 3 doors white frontal  
Jaula exposicion 3 puertas y frontal blanco  
Cage exposition 3 portes frontal blanc

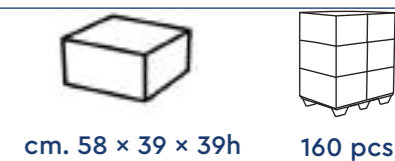

cm. 58 × 39 × 39h 160 pcs

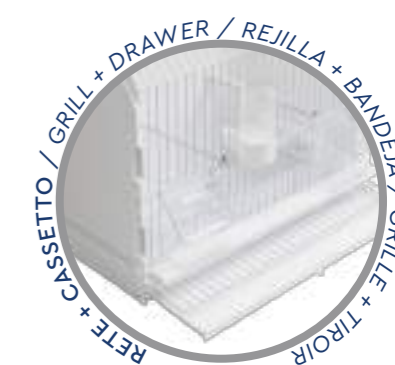

### Art. 315/FB3A

cm. 36 × 17 × 30h  
Gabbia espos. 3 porte frontale bianco  
Exposition cage 3 doors white frontal  
Jaula exposicion 3 puertas y frontal blanco  
Cage exposition 3 portes frontal blanc



MANGIATOIE IN  
POSIZIONE PIÙ ALTA

### Art. 315/FN3

cm. 36 × 17 × 30h  
**Gabbia espos. 3 porte frontale nero**  
 Exposition cage 3 doors black frontal  
 Jaula exposicion 3 puertas y frontal negro  
 Cage exposition 3 portes frontal noir



### Art. 315/FZ3

cm. 36 × 17 × 30h  
**Gabbia espos. 3 porte e frontale zincato**  
 Exposition cage 3 doors galvanized frontal  
 Jaula exposicion 3 puertas y frontal zincado  
 Cage exposition 3 portes frontal zingue

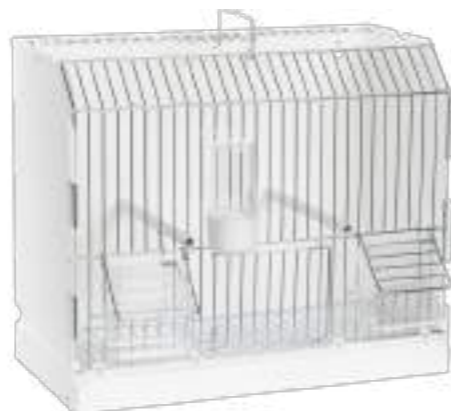

### Art. 315/SC

cm. 36 × 17 × 30h  
**Gabbia espos. 3 porte sistema carta**  
 Exposition cage 3 doors paper system  
 Jaula exposicion 3 puertas sistema papel  
 Cage exposition 3 portes système papier

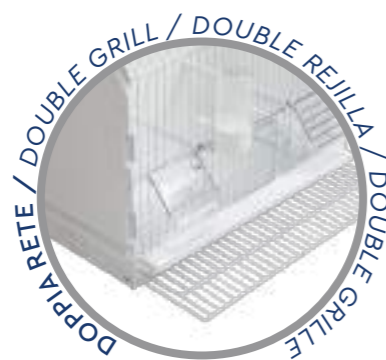

**SISTEMA CARTA**  
 PAPER SYSTEM – SISTEMA  
 PAPEL – SYSTEME PAPIER



cm. 58 × 39 × 39h 160 pcs

### Art. 315/C

**Coperchio per gabbia esposizione art. 315**  
 Cover for exposition cage art. 315  
 Tapa para jaula de exposicion art. 315  
 Couverture pour cage d'exposition art. 315

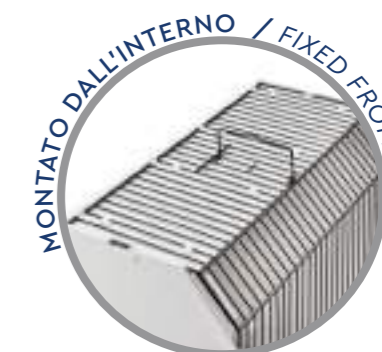

### Art. 315/F

**Cassetto per gabbia esposizione art. 315**  
 Drawer for exposition cage art. 315  
 Bandeja para jaula de exposicion art. 315  
 Tiroir pour cage d'exposition art. 315



### Art. 415

**Carta per gabbia da esposizione 315**  
 Absorbent Paper for exposition cage code 315  
 Carta absorbente para jaula exposicion 315  
 Papier absorbant pour cage 315



### Art. 315/T

**Telaio per gabbia esposizione art. 315**  
 Frame for exposition cage art. 315  
 Telar para jaula de exposicion art. 315  
 Cadre pour cage d'exposition art. 315

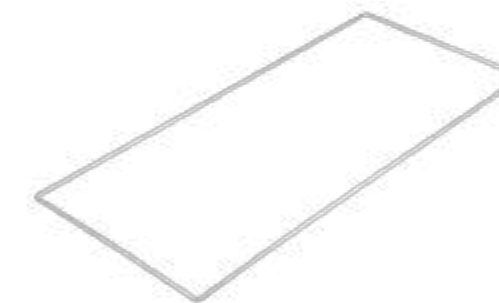

**IDEALE PER TRASFORMARE LA GABBIA IN SISTEMA CARTA**  
 IDEAL TO TRASFORM THE CAGE IN PAPER SYSTEM  
 IDEAL PARA TRANSFORMAR LA JAULA EN SISTEMA PAPEL  
 IDÉAL POUR TRANSFORMER LA CAGE EN SYSTÈME DE PAPIER

### Art. 315/G

**Griglia per gabbia esposizione art. 315**  
 Grill for exposition cage art. 315  
 Rejilla para jaula de exposicion art. 315  
 Grille pour cage d'exposition art. 315



### Art. 315/B

**Bandina per gabbia art. 315**  
 Drawer's cover for cage art.315  
 Frontal para bandeja jaula art. 315  
 Couverture du tiroir cage art. 315





**STRUTTURE PER GABBIE DA ESPOSIZIONE**  
**STRUCTURE FOR EXPOSITION CAGES – ESTRUCTURAS PARA JAULAS**  
**DE EXPOSICION – STRUCTURE POUR CAGE D'EXPOSITION**

**SISTEMA CARTA**  
**PAPER SYSTEM – SISTEMA PAPEL – SYSTEME PAPIER**

**Art. 351**

**Struttura per sistema carta 4 x 5**  
 Structure for paper system 4 x 5  
 Estructura para sistema papel 4 x 5  
 Structure pour système papier 4 x 5



**Art. 354**

- Ø 10 x 18 cm  
**Rotolo di carta**  
 Paper roll  
 Rollo de papel  
 Rouleau de papier



**SISTEMA CON PADELLA**  
**DRAWER'S SYSTEM – SISTEMA CON BANDEJA – SYSTEM AVEC TIROIR**

**Art. 352**

**Struttura per sistema cassetto 4 x 5**  
 Structure for drawer's system 4 x 5  
 Estructura para sistema bandeja 4 x 5  
 Structure pour système avec tiroir 4 x 5

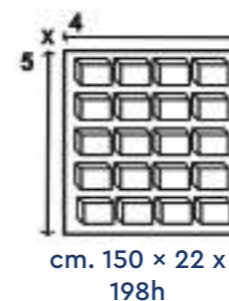

**Art. 353**

**Ruote per struttura singola**  
 Wheels for single structure  
 Ruedas para estructura individual  
 Roues pour structure individuel

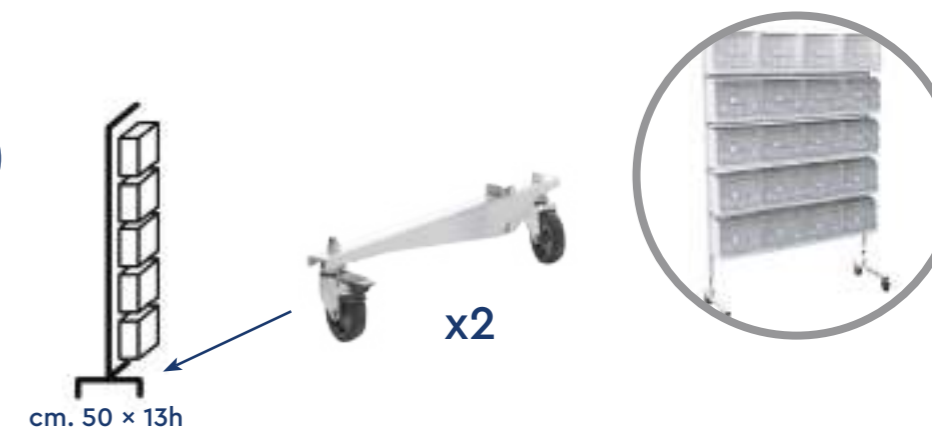

**Art. 443**

— cm. 27,5 × 17 × 20h  
**Gabbia trasportino Brooklyn**  
 Transport cage Brooklyn  
 Jaula transportín Brooklyn  
 Cage de transport Brooklyn

**Art. 445**

— cm. 27,5 × 17 × 35,5h  
**Gabbia New York**  
 Cage New York  
 Jaula New York  
 Cage York

**Art. 444**

— cm. 27,5 × 17 × 27h  
**Gabbia trasportino Manhattan**  
 Transport cage Manhattan  
 Jaula transportín Manhattan  
 Cage de transport Manhattan

**Art. 446**

— **Griglia per gabbia 443 - 444 - 445**  
 Grill for cages 443 - 444 - 445  
 Rejilla para jaulas 443 - 444 - 445  
 Grille pour cages 443 - 444 - 445

**Art.383**

— cm. 22,2 × 14,5 × 2h  
**Griglia per gabbie 20/21/288**  
 Grill for cages 20/21/288  
 Rejilla para jaulas 20/21/288  
 Gril pour cages 20/21/288

**Art. 055**

— cm. 24 × 16 × 19h  
**Gabbia per imbecco**  
 Cage for manual feeding  
 Jaula para empapuzar  
 Cage pour alimentation



**PRIMA DELLE MOSTRE**  
 BEFORE EXHIBITION - ANTES DE LAS EXPOSICIONES - AVANT L'ESPOSITION

**Art. 020**

— cm. 24 × 16 × 20h  
**Gabbia Cantori**  
 Songbird cage  
 Jaula canto  
 Cage pour oiseaux de chant



**DURANTE LE MOSTRE**  
 DURING EXHIBITION - DURANTE LAS EXPOSICIONES - PENDANT L'ESPOSITION

**Art. 377**

— cm. 24,5 × 17 × 18,5h  
**Gabbia Cantori per esposizione**  
 Songbird cage for exhibition  
 Jaula canto para exposiciones  
 Cage oiseaux de chant pour exposition



**PERFETTO PER IL TRASPORTO**  
 SUITABLE FOR TRANSPORT - PERFECTA PARA EL TRANSPORTE - PARFAIT POUR LE TRANSPORT

**Art. 428**

— cm 48 × 22 × 43h  
**Valigia 8 posti verde**  
 Case with 8 places green  
 Maleta con 8 lugares verde  
 Valise avec 8 lieux vert



COPERTA PER QUESTO PRODOTTO DISPONIBILE A PAGINA 16



**Art. 061**

— cm. 28 × 20 × 7h

**Fondo bengalino***Bengalino bottom  
Fondo jaula bengalino  
Fond Bengalino***Art. 062**

— cm. 31 × 20 × 9h

**Fondo jolly***Jolly bottom  
Fondo jaula jolly  
Fond jolly***Art. 075**

— cm. 44 × 27 × 8h

**Fondo gabbia cova***Brooding cage bottom  
Fondo jaula cria  
Fond pour cage de couvée***Art. 079**

— cm. 38 × 24 × 10,5h

**Fondo lusso***Lusso bottom  
Fondo jaula lujo  
Fond luxe***Art. 095**

— cm. 58 × 32 × 9h

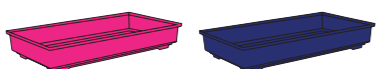
**Fondo gabbia cova***Brooding cage bottom  
Fondo jaula cria  
Fond pour cage de couvée***Art. 114**

— cm. 67,7 × 35,2 × 12,5h

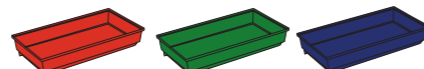
**Fondo cova***Brooding cage bottom  
Fondo jaula de cria  
Fond pour cage de couvée***Art. 042**

— cm. 3,5 × 1,5

**Gancio per fondo gabbia***Hook for cage bottom  
Gancho para fondo de jaula  
Crochet pour fond de cage***Art. 077**

— cm. 5 × 1,5

**Gancio fermafondo lungo***Long hook for cage bottom  
Gancho largo para fondo jaula  
Crochet pour fond de cage***Art. 088**

— cm. 6 × 7

**Portina p/g fili verticali***Door for cage with vertical wires  
Puerta para jaula hierro vertical  
Porte pour grille avec vertical fils***Art. 089**

— cm. 6 × 7

**Portina p/g fili orizzontali***Cage door with horizontal wires  
Puerta para jaula hierro horizontall  
Porte pour grille avec horizontal fils***Art. 388**

cm 7,5 × 6,5h

**Portina in ferro con molla***Iron door with spring  
Porta en hierro con molla  
Porte en fer avec ressort***COMPATIBILE CON GABBIE 315**  
**COMPATIBLE WITH CAGES CODE 315**  
**COMPATIBLE CON JAULAS 315**  
**COMPATIBLE AVEC LES CAGES 315****Art. 135**

— cm. 9 × 10

**Altalena***Swing  
Columpio altalena  
Balançoire*

**Art. 050/E**

**Terminale esterno per posatoio**  
External perch ends  
Terminal externo para posador  
Embout exterieur pour perchoir



Ø10 Ø12

**Art. 050/I**

**Terminale per paletto**  
Perch ends  
Terminal para posador  
Embout perchoir



Ø10 Ø12

**Art. 355**

— cm. 11×7,5×32h  
**Posatoio Sunset**  
Sunset Perch  
Percha Sunset  
Perchoir Sunset

**Art. 085**

— cm. 5  
**Posatoio plastica**  
Plastic perch  
Posador plastico  
Perche plastique

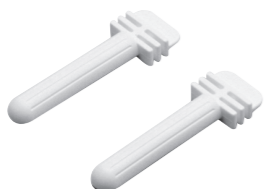
**Art. 272**

— cm. 16,5  
**Posatoio plastica**  
Plastic perch  
Posador plastico  
Perche plastique

**Art. 113**

1 mt.  
**Paletti trafilati**  
Drawn perch  
Percha trefilada  
Perchoir trefilé



Ø 22 / Ø 18 / Ø 12 / Ø 10

**Art. 081**

— cm. 18  
**Posatoio**  
Perch  
Posador  
Perche

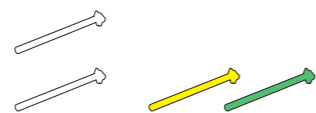
**Art. 080**

— cm. 22  
**Posatoio**  
Perch  
Posador  
Perche

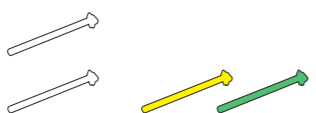
**Art. 124**

**Spazzolino d.16**  
Brush d.16  
Cepillo d.16  
Brosse d. 16

**Art. 124/A**

**Spazzolino d.50**  
Brush d.50  
Cepillo d.50  
Brosse d. 50

**Art. 124/B**

**Spazzolino d. 40**  
Brush d. 40  
Cepillo d. 40  
Brosse d. 40

**Art. 124/C**

**Spazzolino d. 75**  
Brush d. 75  
Cepillo d. 75  
Brosse d. 75



124/A



# UCCELLI SELVATICI

WILD BIRDS / AVES SILVESTRES / OISEAUX DE LA NATURE

## Mangiatoie

Feeders

Comederos

Mangeoires

96



### Art. 148

Kg.1 - lt. 1

**Comber mangiatoia abbeveratoio**  
*Comber feeder/water dispenser*  
*Comber comedero/bebedero*  
*Comber mangeoire/abreuvoir*



### Art. 149

Kg.1 - lt. 1

**Comber mangiatoia/beverino da esterno**  
*External Comber feeder/water dispenser*  
*Comber comedero/bebedero para externo*  
*Comber mangeoire/abreuvoir extérieur*



### Art. 450

— ø 15 × 27 h

**Mangiatoia per semi Kiku**  
*Kiku seeds feeders*  
*Comedero Kiku para semilla*  
*Mangeoire Kiku pour graines*



**IDEALE ANCHE PER VOLIERE!**  
*PERFECT FOR AVIARY*  
*PERFECTO PARA VOLADORAS*  
*IDÉAL POUR VOLIERE*

### Art. 457

— ø 15 × 12,5 × 26 h

**Nido da esterno per uccellini selvatici**  
*External nest for wild birds*  
*Nid exterior para pajaros silvestres*  
*Nid extérieur pour oiseaux sauvages*



### Art. 451

— ø 15 × 27 h

**Mangiatoia per palle di grasso Ume**  
*Ume fat balls feeder*  
*Comedero Ume para bolas de grasa*  
*Mangeoire Ume pour boules de graisse*





# RODITORI E TARTARUGHE

RODENTS & TURTLES / ROEDORES & TORTUGAS / RONGEURS & TORTUES

## Maisonette

98

Maisonette  
Mansion  
Cage pour rongeurs

## Sifoni

100

Siphons  
Bebederos  
Abreuvoir pour rongeurs

## Accessori

101

Accessories  
Accesorios  
Accessoires

## Tartarughiere

102

Turtles tanks  
Tortugueras  
Cage pour tortues





**Art. 280**

— cm. 44 × 34 × 20h  
**Maisonette Candy**  
 Candy hamster cage  
 Jaula para hamster Candy  
 Cage Hamster Candy



**Art. 370**

— cm. 52×38×24h  
**Maisonette Cleo**  
 Cleo hamster cage  
 Jaula para hamster cleo  
 Cage pour hamster Cleo



**Art. 174**

— cm. 50 × 38 × 25h  
**Maisonette Baby**  
 Hamster cage Baby  
 Jaula para hamster Baby  
 Cage Hamster Baby



**Art. 150**

— cm. 60 × 40 × 30h  
**Maisonette**  
 Hamster cage  
 Jaula hamster  
 Cage rongeurs



**Art. 151**

— cm. 60 × 40 × 30h  
**Maisonette lusso**  
 Luxury hamster cage  
 Jaula lujo para hamster  
 Cage hamster luxe



**Art. 153**

— cm. 60 × 40 × 30h  
**Maisonette lusso vuota**  
 Empty luxury cage  
 Jaula lujo vacia  
 Cage vide de luxe



**Art. 126**

— cm 15,5 × 11 × 13h  
**Casetta per criceto**  
 Hamster house  
 Caseta hamster  
 Maison hamster





**Art. 102**

ø 14 x 9h  
**Ruota per criceto chiusa**  
 Closed hamster wheel  
 Rueda para hamster cerrada  
 Roue pour hamster fermé

**Art. 086**

cc. 90  
**Sifone criceto**  
 Hamster siphon  
 Bebedero hamster  
 Abreuvoir Hamster

**Art. 389**

cc. 70  
**Sifone roditori Ghiotto**  
 Ghiotto rodents siphon  
 Bebedero roedor Ghiotto  
 Abreuvoir rongeurs Ghiotto

**Art. 390**

cc. 90  
**Sifone roditori Bijou**  
 Bijou rodents siphon  
 Bebedero roedor Bijou  
 Abreuvoir rongeurs Bijou

**Art. 391**

cc. 200  
**Sifone Jingle**  
 Jingle siphon  
 Bebedero Jingle  
 Abreuvoir Jingle

**Art. 392**

cc. 200  
**Sifone Elliot c/ventose**  
 Elliot siphon w/suction caps  
 Bebedero Elliot c/ventosa  
 Abreuvoir Elliot a/ventouse

**Art. 393**

cc. 400  
**Sifone roditori Elvis**  
 Elvis rodents siphon  
 Bebedero roedor Elvis  
 Abreuvoir rongeurs Elvis

**Art. 166**

ø 32 mm  
**Anello con ventosa**  
 Ring with suction cap  
 Anillo con ventosa  
 Anneau avec ventouse

**Art. 167**

ø 50 mm  
**Anello doppio con ventosa**  
 Double ring with suction cap.  
 Anillo doble con ventosa  
 Anneau avec double ventouse

**Art. 044**

— cm. 7 x 4 x 3h  
**Mangiatoia criceto**  
 Hamster feeder  
 Comedero hamster  
 Mangeoire hamster

**Art. 144**

ø 7 x 3,5h  
**Mangiatoia criceto rotonda con bas**  
 Hamster feeder with base  
 Comedero hamster redondo con base  
 Mangeoire pour hamster avec base

**Art. 165**

— cm. 25 x 9 x 16h  
**Portafieno**  
 Hay holder  
 Porta heno  
 Porteur de foin

**Art. 300**

**Confezione di fibra di cotone per Roditori**  
 Rodent cotton fibre's packaging  
 Confeccion de fibra de cotton para roedores  
 Paquet de fibres de cotton pour rongeurs

**Art. 154**

**Trappola per topi**  
 Mouse trap  
 Trampa para ratones  
 Souricière



**Art. 163**

— cm. 31,5 × 22 × 7h  
**Tartarughiera Oasi**  
 Oasis turtle tank  
 Tortuguera Oasis  
 Bacs à tortues Oasi

**Art. 198**

— cm. 40 × 27 × 9,5h  
**Tartarughiera Oasi Maxi**  
 Oasis Maxi turtle tank  
 Tortuguera Oasis Maxi  
 Bacs à tortues Oasi Maxi

**Art. 183**

— cm. 43 × 32 × 9,5h  
**Tartarughiera Maxi**  
 Maxi turtle tank  
 Tortuguera Maxi  
 Bacs à tortues Maxi

**Art. 164**

ø 24,5 × 6,5h  
**Tartarughiera Laguna**  
 Laguna turtle tank  
 Tortuguera Laguna  
 Bacs à tortues Laguna

**Art. 312**

— cm 44 × 34 × 12h  
**Tartarughiera Ischia**  
 Ischia Turtletank  
 Tortuguera Ischia  
 Bacs à tortues Ischia

**Art. 281**

— cm. 44 × 34 × 20h  
**Tartarughiera Daffy**  
 Daffy turtle tank  
 Tortuguera Daffy  
 Bacs à tortues Daffy

**Art. 371**

— cm. 52×38×24h  
**Tartarughiera Toby**  
 Turtle tank Toby  
 Tortuguera Toby  
 Bacs à tortues Toby

**Art. 372**

— cm. 52×38×24h  
**Tartarughiera Sammy**  
 Turtle tank Sammy  
 Tortuguera Sammy  
 Bacs à tortues Sammy





**Art. 175**

— cm. 50 × 38 × 25h  
**Tartarughiera Baby**  
 Small turtle tank  
 Tortuguera Baby  
 Bacs á tortues Baby



**Art. 152**

— cm. 60 × 40 × 30h  
**Tartarughiera**  
 Turtle tank  
 Tortuguera  
 Bacs á tortues

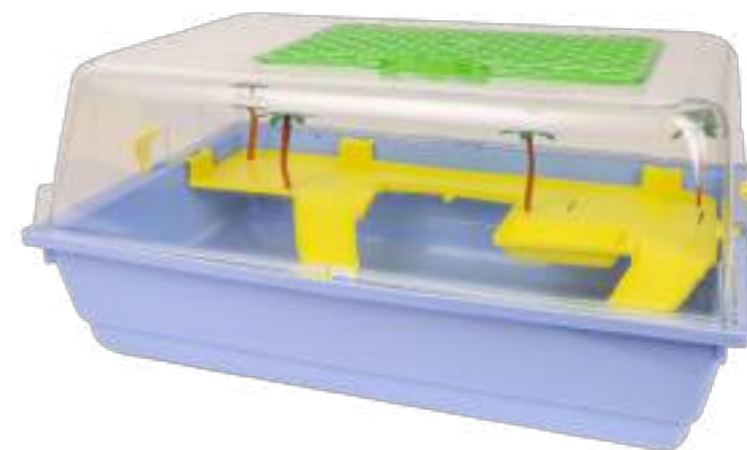

**Art. 176**

— cm. 50 × 38 x25h  
**Tartarughiera Elba**  
 Elba turtle tank  
 Tortuguera Elba  
 Bacs á tortues Elba



**Art. 123**

— cm. 7 × 3  
**Gancio fermafondo universale**  
 Universal bottom hook  
 Gancho universal para fondo  
 Universel crochet



# CANI E GATTI

DOGS & CATS / PERROS & GATOS / CHIENS & CHATS

## Trasportini

105

Transport

Transportin

Cage de transport

## Lettiere

109

Litters

Lettieras

Litières

## Ciotole

110

Bowls

Comederos

Bols





**Art. 286**

— cm. 49 × 33 × 31h  
**Trasportino Calipso**  
 Calipso transporter  
 Transportino Calipso  
 Cage de transport Calipso



**Art. 283**

— cm. 44 × 34 × 12h  
**Toilette Felix con cornice**  
 Complete Felix toilet  
 Bano Felix con cornisa  
 Toilette Felix avec cadre



**Art. 138**

— cm. 49 × 38 × 14,5h  
**Toilette Silvestro completa**  
 Complete Silvestro toilet  
 Toilet Silvestro completa  
 Toilette Silvestro avec cadre



**Art. 189**

— cm. 43 × 26 × 37h  
**Trasportino Penelope**  
 Penelope transporter  
 Transportino Penelope  
 Cage de transport Penelope



**Art. 156**

— cm. 9 × 25 × 3,5h  
**Paletta igienica gatto**  
 Waste shovel  
 Paleta higienica  
 Palette hygienique pour chat



**Art. 143**

— cm. 16 × 40  
**Ricambi sac. Snoopy 24 pz.**  
 Snoopy refill bags 24 pz.  
 Recambio bolsa recogedor higienico Snoopy  
 Pieces de Rechange pour Snoopy



**Art. 357**

**Ciotola Minou**  
Bowl Minou  
Comedero gato Minou  
Bol Minou

**Lt. 0,2**



**Art. 358**

**Ciotola Bizet**  
Bowl Bizet  
Comedero gato Bizet  
Bol Bizet

**Lt. 0,3**



**Art. 359**

**Ciotola Matisse**  
Bowl Matisse  
Comedero gato Matisse  
Bol Matisse

**Lt. 0,5**



**Art. 360**

**Ciotola doppia Romeo**  
Double Bowl Romeo  
Comedero doble Romeo  
Double Bol Romeo

**Lt. 0,3 x 2**



**Art. 162/18**

**Ciotola**  
Bowl  
Comedero  
Bol

**Lt. 1,5**



**Art. 162/20**

**Ciotola**  
Bowl  
Comedero  
Bol

**Lt. 1,2**



**Art. 162/T**

**Ciotola tripla**  
Triple bowl  
Comedero triple  
Triple Bol



**Art. 162/14**

**Ciotola per Cocker**  
Cocker Bowl  
Comedero para Cocker  
Bol pour Cocker

**Lt. 0,85**



**Art. 162/24**

**Ciotola**  
Bowl  
Comedero  
Bol

**Lt. 3,5**



**Art. 162/26**

**Ciotola**  
Bowl  
Comedero  
Bol

**Lt. 6**





CODICE	DESCRIZIONE	PAG
001/A	Scheda a 4 cove	57
003	Mangiatoia ganci plastica	42
005	Mangiatoia colombi griglia plastica	44
006	Mangiatoia colombi griglia ferro	44
007	Molletta gancio	46
008	Nido piccolo	50
009	Nido grande	50
010	Uova piccole	59
010/C	Uova piccole colorate	59
011	Uova grandi	59
012	Mangiatoia att. dir. piccola	35
013	Mangiatoia att. dir. grande	35
015	Mangiatoia pappagallo c/ferri	41
017	Mangiatoia Napoli	32
018	Beverino corto	26
018/F	Beverino corto fumè	26
020	Gabbia cantori da preparazione	87
022	Mangiatoia piccola c/ferri	40
022/G	Mangiatoia piccola c/ferri con griglia	40
024	Mangiatoia esterna	33
025/G	Mangiatoia universale con griglia	43
026	Portanido in ferro Ø 10	51
028	Mangiatoia mezzaluna	34
033	Portaseppia g/plastica	46
034	Sifone Firenze	26
035	Mangiatoia mezzaluna ganci	34
036	Laterale in plastica per gabbia cova 55	60
037/A	Bandina frontale gabbia cova 55	60
038	Sifone lungo	26
039	Nido interno	50
041	Portasali	45
042	Gancio per fondo gabbia	87
043	Mangiatoia rett. media c/alette	41
044	Mangiatoia criceto	101
045	Mangiatoia piccola rett. c/ferri	40
046	Vaschetta bagno interna	47
049	Bagno Reggio	47
050/I	Terminale per paletto	90
050/E	Terminale esterno per posatoio	90
051	Mangiatoia Reggio	43
052	Mangiatoia Reggio c/ferri	43
053	Mangiatoia Parma	40
054	Mangiatoia Parma c/ferri	40
055	Gabbia per imbecco	86
056	Nido esterno ferro/pl.	50

CODICE	DESCRIZIONE	PAG
057	Portamedicinali	46
058	Sifone per polli	32
059	Nido esterno lusso	50
059/V	Nido esterno lusso	50
060/A	Sifone Lucca con anello	27
061	Fondo bengalino	88
062	Fondo jolly	88
064	Fondo gabbia cova 55	60
065	Sifone mang. pappagalli	31
066	Sifone Napoli	31
068	Sifone Reggio	27
069	Portauovo	46
070	Portabiscotto	46
071	Mangiatoia girasole	45
072	Mangiatoia ovale	45
073	Mangiatoia girasole c/base	45
074	Bagno esterno lux	47
075	Fondo gabbia cova	87
077	Gancio fermafondo lungo	87
078	Pinza Reggio	59
079	Fondo lusso	87
080	Posatoio	90
081	Posatoio	90
082	Portaseppia	46
083	Nido perla	54
084	Nido diamante	54
085	Posatoio plastica	90
086	Sifone criceto	100
087	Sifone banana	27
088	Portina p/g fili verticali	89
089	Portina p/g fili orizzontali	89
094	Portapastoncino lusso	45
094/A	Portapastoncino lusso alto	45
095	Fondo gabbia cova	87
097	Raccoglitore universale	56
097/P	Raccoglitore universale pieno	56
098	Mangiatoia per voliera bianca	44
099	Mangiatoia per voliera trasparente	44
100	Mangiatoia per voliera trasparente c/ferri	43
101	Mangiatoia per voliera bianca c/f	43
102	Ruota per criceto chiusa	100
103	Mangiatoia Spagna 2000	33
105	Mangiatoia Italia 2000	33
113	Paletti trafilati	113

CODICE	DESCRIZIONE	PAG
114	Fondo cova	87
115	Mangiatoia economy Ø 24	39
115/A	Mangiatoia economy Ø 28	39
116	Mangiatoia economy Ø 24	39
116/A	Mangiatoia economy Ø 28	39
117	Mangiatoia economy plus	39
118	Porta juta	56
118/P	Porta juta pieno	56
119	Mangiatoia Titti	45
122	Porta verdure e juta	46
123	Gancio fermafondo universale	125
124	Spazzolino Ø 16	91
124/A	Spazzolino Ø 50	91
124/B	Spazzolino Ø 40	91
124/C	Spazzolino Ø 75	91
125	Mangiatoia piccola g/plastica	41
126	Casetta per criceto	99
127	Mangiatoia pappagallo g/plastica	41
128	Beverino lungo lusso	24
129	Erogatore magic	29
130	Beverino magic	30
131	Sifone Marta	25
134	Sifone Firenze lusso	26
135	Altalena	89
138	Toilette Silvestro completa	109
142	Pinza universale	46
143	Ricambi sac. Snoopy 24 pz.	109
144	Mangiatoia criceto rotonda con base	101
146	Beverino per medicinali	23
147	Mangiatoia "lusso"	33
148	Comber-mangiatoia abbevert.	94
149	Comber-mangiatoia esterno	94
150	Maisonette	99
151	Maisonette lusso	99
152	Tartarughiera	105
153	Maisonette lusso vuota	99
154	Trappola per topi	101
155	Mangiatoia economy dispenser	39
156	Paletta igienica gatto	109
158	Beverino corto lusso	24
160	Mangiatoia Milano	33
162/18	Ciotola Lt. 1,5	111
162/20	Ciotola Lt. 1,2	111
162/24	Ciotola Lt. 3,5	111
162/26	Ciotola Lt. 6	111

CODICE	DESCRIZIONE	PAG
162/T	Ciotola tripla	111
163	Tartarughiera Oasi	102
164	Tartarughiera Laguna	102
165	Portafieno	101
166	Anello con ventosa Ø 32 mm	101
167	Anello doppio con ventosa Ø 50 mm	101
169	Mangiatoia economy Diamant	39
170	Beverino Aves	30
171	Beverino Aves	30
172	Mangiatoia Ines	41
173	Mangiatoia Dalia	41
174	Maisonette Baby	98
175	Tartarughiera Baby	104
176	Tartarughiera Elba	104
181	Nido Samsara completo estraibile Ø 10	49
182	Ciotola nido	51
183	Tartarughiera Maxi	102
184	Sifone Leo	23
185	Mangiatoia Hasselt	32
186	Porta	32
189	Trasportino Penelope	108
190	Mangiatoia Toledo	44
198	Tartarughiera Oasi maxi	98
199	Mangiatoia Piacenza	32
200	Trasportino con griglia fissa e mangiatoia esterna	7
201	Trasportino con griglia fissa e mangiatoia interna	8
202	Trasportino con griglia telescopica	9
203	Tino + n. 6 Secondino	12
204	Trasportino per ondulati a 5 posti	10
205	Trasportino per medie taglie a 5 posti	11
206	Beverino rettangolare	20
207	Coperchio con maniglia	7
208	Ruote	21
209	Divisoria per Tino	21
210	Gancio	20
211	Griglia per art. 200	22
212	Griglia per art. 201	22
213	Griglia per art. 202	22
214	Mangiatoia rettangolare	20
215	Parete estraibile per Tino	21
216	Posatoio per art. 200-201-202	20
217	Coperchio per Maxi Tino	11
218	Tino vuoto	8

CODICE	DESCRIZIONE	PAG
219	Salva-goccia per art. 129	29
220	Trasportino singolo per taglie fino 14 cm	12
221	Beverino Secondino	24
222	Sifone universale	25
223	Nido completo estraibile Ø 8	49
224	Ciotola nido	51
225	Valigia completa di 10 Secondini	14
226	Valigia vuota	14
227	Parete estraibile per Maxi Tino	21
228/A	Divisoria per Maxi Tino	21
228/C	Divisoria per Maxi Tino	21
229	Griglia per art. 204	22
230	Griglia per art. 205	22
232	Mangiatoia interna con ganci	33
233	Trasportino per trasporto collettivo retro chiuso	11
234	Maxi Tino + n. 10 Secondini	13
235	Tino Economy	6
236	Divisoria per Tino Economy	21
237	Supporti per secondino	21
238	Griglia per art. 235	22
239	Maxi Tino vuoto con supporti	13
240	Beverino Dino	24
242	Trasporto singolo per taglie fino 28 cm	19
244	Trasporto singolo per taglie fino 18 cm	15
245	Maxi Tino + n. 5 Secondini maxi	19
247	Gancio per coperchio valigia art. 225	20
248	Beverino Secondino maxi	20
249	Posatoio per art. 235	20
250	Interno completo x art. 200	7
251	Interno completo x art. 201	8
252	Interno completo x art. 202	9
253	Mangiatoia "Ara" piccola	31
254	Mangiatoia "Ara" media	31
255	Mangiatoia multipla	44
256	Valigia 6 posti per art. 244	15
257	Valigia 8 posti per art. 244	16
258	Valigia 12 posti per art. 244	16
259	Valigia 18 posti per art. 244	17
260	Carrello con 160 secondini medi	18
261	Valigia vuota 6 posti	15
262	Valigia vuota 8 posti	16
263	Valigia vuota 12 posti	16
264	Valigia vuota 18 posti	17

CODICE	DESCRIZIONE	PAG
272	Posatoio plastica	90
273	Carrello con 60 secondini medi	18
273/A	Modulo superiore con 24 secondini	18
273/B	Modulo inferiore con 36 secondini	18
273/C	Comp. trasformazione ruote removibili	18
274	Sifone Aosta corto	23
275	Sifone Ferrara	25
276	Copertura x valigia 6 posti	15
277	Copertura x valigia 8 posti	16
278	Copertura x valigia 12 posti	16
279	Copertura x valigia 18 posti	17
280	Maisonette Candy	98
281	Tartarughiera Daffy	102
283	Toilette Felix con cornice	109
284	Sifone Aosta lungo	23
285	Sifone Livorno	25
286	Trasportino Calipso	108
290/8	Fondello nido in vimini Ø 8	55
290/9	Fondello nido in vimini Ø 9	55
290/10	Fondello nido in vimini Ø 10	55
290/11	Fondello nido in vimini Ø 11	55
290/12	Fondello nido in vimini Ø 12	55
290/15	Fondello nido in vimini Ø 15	55
291	Fondello nido in juta Ø 8/10/12	54
292	Fondello nido in juta-cotone Ø 8/10/12	54
293	Fondello nido in poliestere Ø 10	54
294	Confezione di juta	56
295	Juta-cotone	56
296	Confezione di filo di cotone	56
297	Cocco-Sisal-Juta-Cotone	56
298	Cocco-Sisal-Meliga-Brattea	56
299	Nido goccia in vimini	54
300	Fibra di cotone per roditori	101
301	Tubo diam. int. 4 per art. 129	29
302	Tubo diam. int. 8 per art. 219	29
303	Raccordo a "T" per tubo art. 301	29
304	Uova medio Parrocchetto	59
305	Uova grandi Parrocchetto	59
306/MIX	Anelli in plastica multicolore Ø 3 mm	58
306/MONO	Anelli in plastica monocolore Ø 3 mm	58
307	Anelli "click" in plastica Ø 8/12/16	58
308	Anelli in alluminio Ø 2,5/3/4/6/8/10/12	58
309	Tronchese inox per anellini	58
310	Beverino Capri	30

CODICE	DESCRIZIONE	PAG
311	Beverino Giglio	30
312	Tartarughiera Ischia	102
313	Mangiatoia Olanda c/ganci plastica	42
314	Mangiatoia Olanda c/ganci in ferro	42
315/B	Bandina Gabbia Espositore	83
315/C	Coperchio per gabbia esp. art. 315	83
315/F	Cassetto per gabbia esp. art. 315	83
315/G	Griglia per gabbia espos. art. 315	83
315/FB1	Gabbia espos. 1p. frontale bianco	80
315/FB3	Gabbia espos. 3p frontale bianco	81
315/FB3A	Gabbia espos. 3p frontale bianco	81
315/FN1	Gabbia espos. 1p.frontale nero	80
315/FN3V	Gabbia espos. verde 3p. frontale nero	81
315/FN3	Gabbia esp. 3p. frontale nero	82
315/FZ3	Gabbia espos. 3 p. frontale zincato	82
315/SC	Gabbia espos. 3p. sistema carta	82
315/SP	Gabbia espos. c/foro laterale	80
315/T	Telaio per gabbia esposizione art. 315	83
317/B	Gabbia cova plastificata	61
317/Z	Gabbia cova zincata	61
318	Bagno esterno con ganci in plastica	47
320	Antispreco per art. 313/314	42
321	Sifone Bari	31
322	Porta sali Valencia	45
323	Mangiatoia eclissi	37
323/G	Gancio per attacco universale Mang. Eclissi	38
323/I	Supporti attacco interno gabbia Mang. Eclissi	38
324	Mangiatoia per svezamento	42
325	Nido medio	50
326/B	Gabbia cova	62
326/Z	Gabbia cova zincata	62
326/SC	Gabbia cova	63
327	Laterale in plastica per gabbia cova 58	64
328	Cassetto per gabbia cova 58	64
330	Guida per divisorio	65
331	Divisorio chiuso per gabbia cova 58	65
332	Griglia per gabbia cova 58	65
333	Griglia incurvata per gabbia cova 58	65
334	Gancio ferma griglia	64
335	Mangiatoia Amsterdam	32
336	Coperchio per mangiatoia mezzaluna	34
337	Sistema voliera	64
338	Rubinetto per tubo art. 301	29

CODICE	DESCRIZIONE	PAG
339	Serbatoio per impianto a goccia	29
340	Struttura per sistema carta 2X4	75
341	Struttura per sistema carta 4X4	75
342	Struttura per sistema cassetto 2X4	76
343	Struttura per sistema cassetto 4X4	76
344	Ruota per struttura singola art. 340/342	81
345	Struttura doppia per sistema carta 2X4	77
346	Struttura doppia per sistema carta 4X4	77
347	Struttura doppia per sistema cassetto 2X4	78
348	Struttura doppia per sistema cassetto 4X4	78
349	Rotolo di carta 12X33	79
350	Posatoio per gabbia da cova	65
351	Struttura per sistema carta 4X5	84
352	Struttura per sistema cassetto 4X5	85
353	Ruote per struttura singola	85
354	Rotolo di carta 10X18	84
355	Posatoio Sunset	91
356	Gancio per unione gabbia cm 58	64
357	Ciotola Minou Lt. 0,2	110
358	Ciotola Bizet Lt. 0,3	110
359	Ciotola Matisse Lt. 0,5	110
360	Ciotola doppia Romeo Lt. 0,3x2	110
361	Sifone Revolution cc 72	28
362	Sifone Revolution cc 105	28
363	Sifone Revolution cc 140	28
364	Sifone Revolution cc 200	28
365	Sifone Revolution cc 260	28
366	Sifone Revolution cc 400	28
370	Maisonette Cleo	98
371	Tartarughiera Toby	103
372	Tartarughiera Sammy	103
374	Nido Paradise	52
375	Parete retro per gabbia cova cm 58	63
376	Nido Interno in plastica Relax Ø 10	51
377	Gabbia cantori da esposizione	87
379	Scheda cova per nido 181/223	49
380	Sifone Amalfi	25
381	Nido in gommapiuma Ø 10	51
382	Fondello in gommapiuma Ø 12	51
383	Griglia per gabbie 20/21/288	86
384	Porta-scheda Twister	57
385	Schedina Twister	58



CODICE	DESCRIZIONE	PAG
386	Sifone Venezia	23
387	Sifone Pisa	23
388	Portina in ferro con molla	89
389	Sifone Ghiotto con ventose cc 70	100
390	Sifone Bijou cc 90	100
391	Sifone Jingle con anello cc 200	100
392	Sifone Elliot con ventose cc 200	100
393	Sifone Elvis con anello cc 400	100
394	Portanido in ferro Ø 8	51
395	Anello per beverini cc 400	27
396	Cassetto gabbia cova 120	71
397	Laterale in plastica per gabbia cova 90 e 120	71
398	Kit voliera gabbia cova 90 e 120	72
399	Parete retro per gabbia 120	72
400	Gabbia cova 120 Cortina	69
401	Gabbia cova 120 Bormio	69
402	Gabbia cova 120 Sestriere	70
403	Gabbia cova 120 Livigno	70
404	Griglia bianca per gabbia cova 120	71
405	Griglia zincata per gabbia cova 120	71
407	Posatoio con perno per gabbia 90 e 120	73
408	Posatoio per gabbia 90 e 120	73
409	Maniglia universale	73
410	Porta mangiatoia interno	73
411	Divisorio in plastica per cova 90 e 120	71
413	Divisorio in ferro per cova 90 e 120	72
414	Cassetto gabbia cova 90	71
416	Parete retro per gabbia cova 90	74
417	Kit guide per gabbia cova 90	74
418	Carrello 120 per gabbie cova	74
419	Carrello 180 per gabbie cova	74
420	Gabbia cova 90 Positano	68
421	Gabbia cova 90 Portofino	68
423	Griglia bianca per gabbia cova 90	71
424	Carta bulinata per cova 58	65
425	Carta bulinata per cova 120	73
426	Carta bulinata per cova 90	73
427	Nido Agapornis	53
427T	Coperchio per nido Agapornis	53
428	Valigia 8 posti verde	87

CODICE	DESCRIZIONE	PAG
429	Carrello 90 per gabbie cova	74
430	Mangiatoia componibile Recupera	35
432	Nido per esotico	54
432/G	Ganci per nido esotico	54
433	Mangiatoia Unika	36
435	Bagnetto Esterno Garda	47
437	Easy Nest	49
438 B	Bagno esterno Como	48
438 T	Bagno esterno Como	48
440	Portamedicinali Vitality	46
441 T	Bagno esterno Braies	48
441 W	Bagno esterno Braies	48
442	Divisorio in plastica grigliato	71
443	Gabbia trasportino Brooklin	86
444	Gabbia trasportino Manhattan	86
445	Gabbia New York	86
446	Griglia per gabbia 443 - 444 - 445	86
448	Mangiatoia Refill	37
449	Mangiatoia Refill spagna	37
450	Mangiatoia per semi kiku	95
451	Mangiatoia per palle di grasso Ume	95
454	Carrello 58 per gabbia cova	79
455	Carrello 60 per gabbia cova	74
457	Nido esterno per uccellini selvatici	94
458	Maxi Tino griglia telescopica	10
460	Gabbia cova 60 Taormina	66
461	Gabbia cova 60 Tropea	66
462	Gabbia cova 60 Porto Cervo	67
463	Gabbia cova 60 Polignano	67



KLIMANEUTRAL. I nostri clienti possono contribuire alla salvaguardia del pianeta, scegliendo di certificare i propri stampati "Klimaneutral". Il meccanismo che sta alla base della "stampa climaticamente neutrale" è un sofisticato sistema per il calcolo delle emissioni di gas serra che tiene conto di moltissimi fattori: dai materiali all'energia, dagli inchiostri ai solventi, fino alla confezione ai trasporti e allo smaltimento. Grazie a ciò, l'impatto (carbon footprint) dei nostri prodotti viene quantificato in tonnellate equivalenti di CO2 e può essere compensato attraverso l'acquisto e lo scambio di quote di emissione finanziando al contempo eco-progetti a livello internazionale (come ad esempio la costruzione di una nuova centrale eolica).



Il marchio della gestione forestale responsabile



**2GR SRL**

Via Verzelloni, 14 - 42015 Correggio (RE) - Italy

Tel. +39.0522.694935

[www.2g-r.it](http://www.2g-r.it) | [info@2g-r.com](mailto:info@2g-r.com)

Cod. Fisc. Part. IVA 00905560355